

Lesson 1
ELECTRON THEORY AND MAGNETISM

Task. The skills and knowledge taught in this lesson are common to all missile repairer tasks.

Objectives. When you have completed this lesson, you should be able to describe the principles of electron flow, static electricity, conductors, and insulators and discuss basic electrical concepts and principles of magnetism.

Conditions. You will have this subcourse book and work without supervision.

Standard. You must score at least 70 on the end-of-subcourse examination that covers this lesson and lessons 2, 3, and 4 (answer 27 of the 38 questions correctly).

ELECTRON THEORY

Basic Concepts of Matter

The electron theory, which is now accepted and used to explain the behavior of electricity, states that electric current consists of electron flow and can be defined as a moving charge. Electricity can be defined, then, as charged matter. Because an electron, even though smaller than the smallest known microscopic organism, has mass and occupies space, it is matter. To understand what an electron is, you need first to understand the structural nature of matter.

Matter is basically composed of two kinds of electricity (positive and negative). The electron is the basic unit of negative electricity and the proton is the basic unit of positive electricity. There is also a neutral particle called the neutron.

Molecules

Matter exists in three states; solid, liquid, and gas. You are familiar with water in each of its three states; ice, water, and steam. Regardless of its state, all matter is composed of small particles known as molecules. Solids, liquids, and gases differ in the spacing and forces between the molecules. You know it takes more force to separate ice than it does liquid water. The molecules in gas (steam) will separate themselves if left alone. Molecules in any state are in constant motion.

The molecule is the smallest component into which a compound can be sub-divided by physical means. Boiling water subdivides into separate molecules without changing the chemical composition of the molecules. This is a physical change. To subdivide the molecule into its components requires a chemical change.

MM0703, Lesson 1

Molecules are composed of atoms. A substance which contains atoms of one kind only is called an element, while those containing more than one kind are called compounds or mixtures. When two or more atoms combine, they form a molecule. If these atoms are not all alike, then the substance formed is a compound. Oxygen and hydrogen are both examples of an element. When one oxygen atom and two hydrogen atoms unite, they form a molecule of water. Water is a compound.

Atoms

As mentioned above, molecules are composed of even smaller particles known as atoms. According to the present concept, an atom is one or more negatively charged particles called electrons, revolving at great speeds in regular, circular, or elliptical orbits around a positive nucleus. The nucleus is one or more positively charged particles called protons and a number of uncharged particles called neutrons. A typical atom, lithium, is shown in figure 1-1.

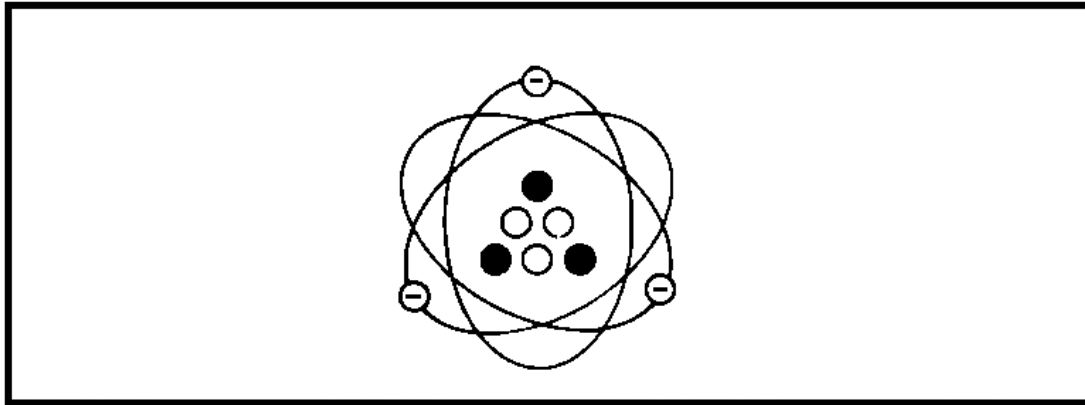

Figure 1-1. Atomic Structure as Shown by Lithium.

According to present theory, the nucleus of an atom always has the same number of protons in it as it has electrons outside of it. Uncharged particles, neutrons, are found in the nucleus and add weight to the atom. A proton and a neutron have the same weight, and each is approximately 1,845 times heavier than an electron. The difference between the different atoms is in the number and arrangement of the protons and electrons. Atoms of each of the known elements are of a different weight and size and have distinguishing characteristics.

Figure 1-2 shows the three atoms that make up a molecule of water. It consists of two hydrogen atoms and one oxygen atom. In the hydrogen atom, the nucleus contains one proton (+) whose positive charge is balanced by the negative charge of its one electron (-). In the oxygen atom, the nucleus contains eight protons whose positive charge is balanced by the negative charges of the eight electrons.

The hydrogen atom in figure 1-2 is the lightest of all atoms, with its single proton and single electron. Some of the heavier atoms (those of the heavier metals such as gold) have over 90 electrons. In the normal atom, the sum of the positive charges of the protons in the nucleus equals exactly the sum of the negative charges of the electrons. Such an atom is neutral.

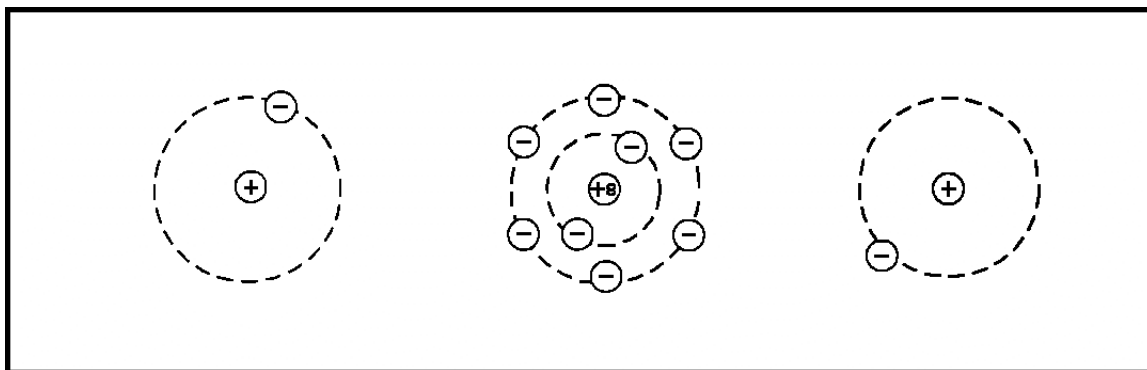

Figure 1-2. Atoms in a Molecule of Water.

Ions and Ionization

Under normal conditions, atoms are neutral. However, if for some reason a few electrons are torn away from a neutral atom, the atom becomes "charged" and is called a positive ion. Whereas, if the electrons that are torn away from the neutral atom gather on some other neutral atom, that atom becomes negatively charged and is called a negative ion. In other words, an ion is what is left after an electron has been knocked loose from a neutral atom, or what is created after an electron is added to a previously neutral atom.

The process of an atom gaining electrons or losing electrons is called ionization. Any atom or molecule which carries either a positive or a negative charge is ionized.

Some materials, such as table salt and sulfuric acid, become ionized when mixed with water. The solution as a whole, however, remains neutral. Ionization in gases may result from the collision of two gas molecules, by electron bombardment, or by illumination with a certain kind of light.

The protons within an atom are much heavier than the electrons. Therefore, in an atom of gas, the electrons knocked loose when ionization occurs will move much more easily if some electric force is applied than will the much heavier protons. Ionization of gases is important to you because it happens in electronic equipment, such as radio and television receivers. During the study of electron tubes, many of which are similar to those in home radio receivers, you will see that ionization is sometimes desirable and at other times undesirable.

Static Electricity

Although this course is mainly about charges in motion, a good understanding of static fields will be helpful to you.

That certain objects attract paper and other light materials when rubbed with various kinds of cloth has been known a long time. The early Greeks were familiar with this method of producing what is now called static electricity. They knew that amber, which they called electron, attracted light objects when rubbed with cloth. The English words *electron* and *electricity* are derived from this Greek word for amber. A great deal of our early knowledge about electricity was obtained by experiments on charged bodies, or electricity, at rest.

MM0703, Lesson 1

When static electricity converts to energy, the effects can sometimes be quite startling. Lightning discharges and the crackling sound in a radio receiver are manifestations of static electricity, releasing its stored up energy.

Charged Bodies and the Force Between Them. Bodies can be charged with static electricity various ways. To understand how, you need to know the following. A charged body merely means that the object has more or less than its normal number of electrons. In the uncharged state, each atom has an equal number of electrons and protons; therefore, in order to charge a body positively, it is necessary to remove some of the electrons. When that happens, there will be an excess of protons or positive charges. The electrons, which were removed are now on some other object, causing it to be negatively charged. (Recall both negatively and positively charged atoms are ions.)

It has been proved experimentally that charged bodies act upon each other with a force of attraction when their charges are unlike and a force of repulsion when their charges are like. Thus, the conclusion is that electrons and protons attract each other, that electrons repel other electrons, and that protons repel other protons. This attraction and repulsion may be stated as the following laws:

- Electric charges of like kind repel each other and charges of unlike kind attract each other.
- The forces of attraction and repulsion are directly proportional to the product of the charges and inversely proportional to the square of the distance between them.

While a unit of electrical charge could be taken as the charge associated with an electron or proton, it would not be practical because it is so small. A more practical unit of charge, called a coulomb, is used. It is about equal to a charge of 6.28×10^{18} electrons. The coulomb derives its name from Charles A. Coulomb, a Frenchman who reduced the two laws above to the following formula or law:

The law (Coulomb's Law) can be expressed algebraically as:

$$F \text{ (dynes)} = \frac{Q_1 Q_2}{Hd^2},$$

where Q_1 and Q_2 represent the charges in electrostatic units (2.1×10^9 electrons), d the distance in centimeters separating them, and K a constant which depends upon the material separating them. F (dyne) means force in the form of dynes. A dyne is that force which will give an acceleration of 1 centimeter per second, during each second, to a free mass of 1 gram.

Electrostatic or Dielectric Field of Force. The region surrounding and between charged bodies is called the electrostatic field of force. Since this force will act through free space or even through a vacuum, it is different from ordinary forces such as those caused by striking a sharp blow or by exerting steady pressure, like the pressure of water on a dam or the pressure of the air inside an automobile tire. These methods of applying force involve some mechanical connecting link. A field of force differs from these in that it requires no physical or mechanical connecting link, but can be applied through space or through a vacuum.

In order to visualize the various properties of fields of force and their relation to electrical phenomena, you can represent them by imaginary lines that show the direction and intensity of the field. Since it is impossible to imagine enough lines to represent all the paths through space along which the force acts, only a few are drawn, and those only in one plane. The force direction is indicated by an arrowhead and the field strength (or intensity) is indicated by the density or number of lines per unit area. The direction of force is the direction a small positive test object moves or tends to move when acted on by the force.

To test the direction of an electric field, the test object would have to be either a small positive charge or a small negative charge, because the force of a dielectric field will act on either. Scientists use a small positive charge for determining the direction of a dielectric field, and so, this subcourse does, too. (A dielectric field is a field of force that exists between two charged bodies.) In other words, the field about an isolated positive charge (figure 1-3), is away from the charge because a positive test charge would be repelled. The field about an isolated negative charge (figure 1-3), is toward the charge, because a positive test charge would be attracted. The field between a positive and negative charge is from positive to negative for the same reason.

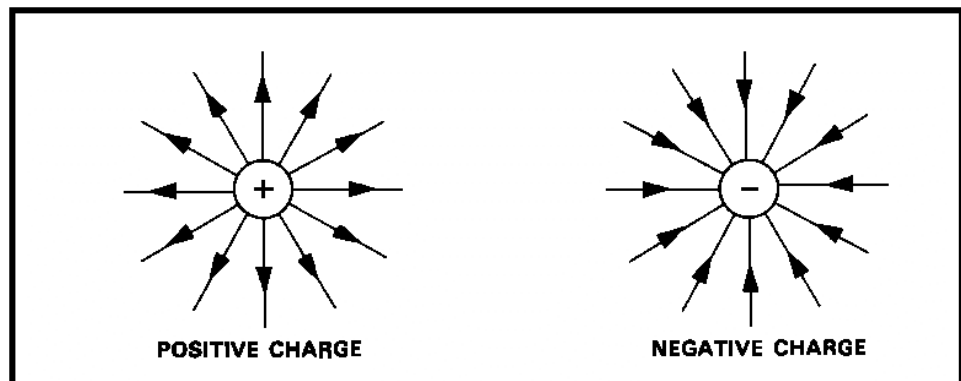

Figure 1-3. The Fields of Force About Single Charges.

Note in figures 1-4 and 1-5 how lines of force apparently repel each other. In figure 1-4, although the two charges are attracted, the lines of force between the two are not parallel but bulge out at the center as if they were repelling each other. Also note that where they bulge at the center, they are in the same direction; that is, from right to left on the paper.

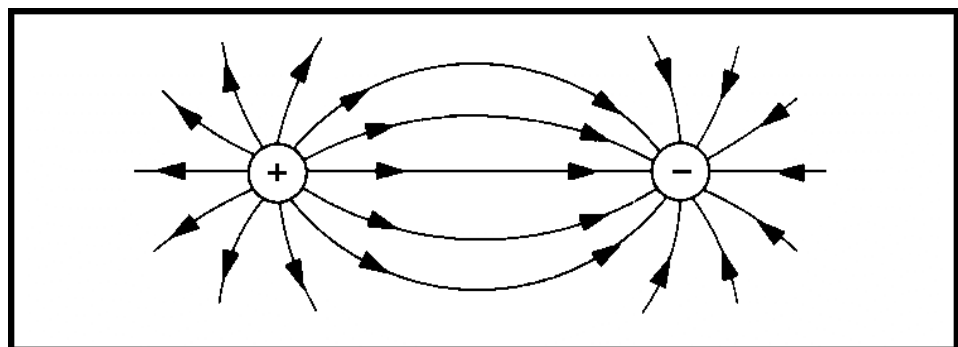

Figure 1-4. Dielectric Field About Two Unlike Charges.

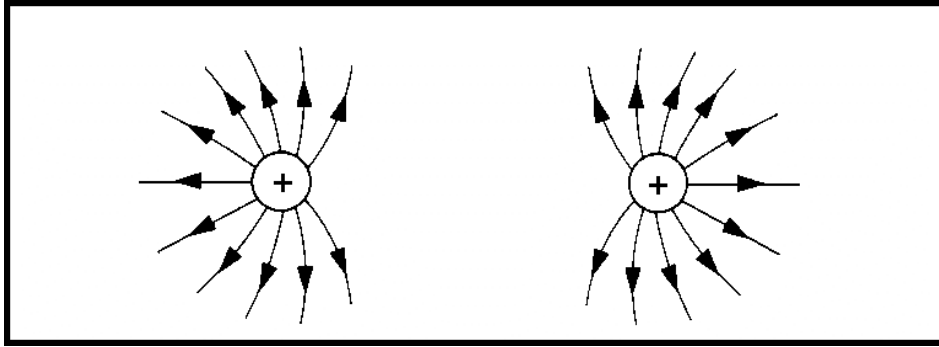

Figure 1-5. Dielectric Field About Two Like Charges.

In figure 1-5, the lines of force which are in the region between the charges apparently are repelling each other, as you can judge by the direction of their bends. Although you can say, "like charges repel," the law is stated: Dielectric lines of force in the same direction repel each other. In dealing with certain electric phenomena, this rule is very convenient and useful.

If you briskly rub a rubber rod or comb over a piece of fur or woolen cloth a number of electrons from the fur or cloth adhere to the rubber. If you separate the two immediately, the rubber has an excess of electrons (is negatively charged). If you charge two pith balls oppositely by touching one of them with the rubber and the other with the cloth or fur, they will have an attraction for each other, showing that a force is present. See figure 1-6. You have established a dielectric field. If you allowed the bodies to come together after having been pulled apart, the energy expended in separating them would be regained in the form of force of attraction. This means that energy can be stored in a dielectric field.

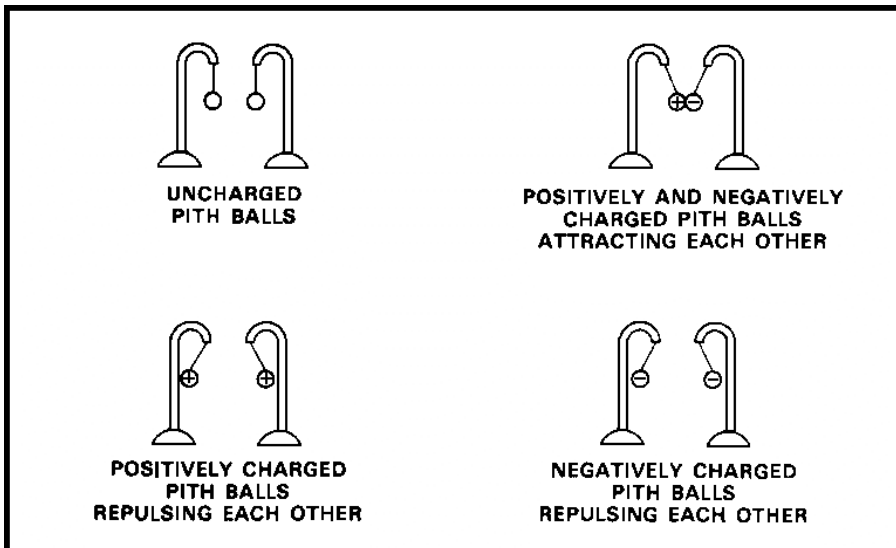

Figure 1-6. Pith Ball Experimentation With Dielectric Fields.

Even if you move the negatively charged rubber rod some distance away from the cloth or fur, a dielectric field still exists in the space around it. You can see it demonstrated by picking up small bits of paper with the rod or by charging

both of the pith balls from it. The pith balls would then show a force of repulsion between them, indicating the pressure of a dielectric field.

If you use an external force to bring the two charged pith balls closer together, work is done, and the force of repulsion is increased due to the decrease of the natural distance between the two charged bodies. The energy used in decreasing this distance (recovered when you remove the external force) will be used in returning the pith balls to their original position. Here again, it is shown that energy is necessary to establish a force and that the recovered energy has been stored in the field.

If you isolate one negatively charged pith ball and bring the negatively charged rubber rod toward it from any direction, a force of repulsion will be present. If the pith ball is positively charged, it will have an attraction for a negative charge in any direction. The conclusion is that a dielectric field entirely surrounds a charged body.

The Electroscope. It has been shown experimentally that an electric charge can be detected because it attracts light objects such as pith balls, bits of paper, etc.

Any device used for detecting electric charges is called an electroscope. In its simplest form, an electroscope consists of a pith ball hanging on the end of a silk thread. By touching it with a body of a known charge, you have an instrument that can detect charged bodies and that can indicate the type of charge (polarity). To illustrate, if you touch the pith ball with a glass rod, which has been rubbed with silk, you charge the pith ball positively. Any other charged body that is brought near the pith ball will repel it if the body is positive or attract it if the body is negative. The force of repulsion or attraction indicates the strength of the field surrounding the charged bodies.

A better and more sensitive device is the leaf electroscope shown in figure 1-7. It is two thin sheets of metal foil (usually gold or aluminum) called leaves, supported by a wire or stem whose ends pass through a block of sealing wax or insulating material to a metal ball or cap. The leaves are usually sealed in a glass container to prevent air currents and moisture from affecting the instrument. The sensitivity of the instrument depends on several factors, the main two being the thickness and the type of material the leaves are made of.

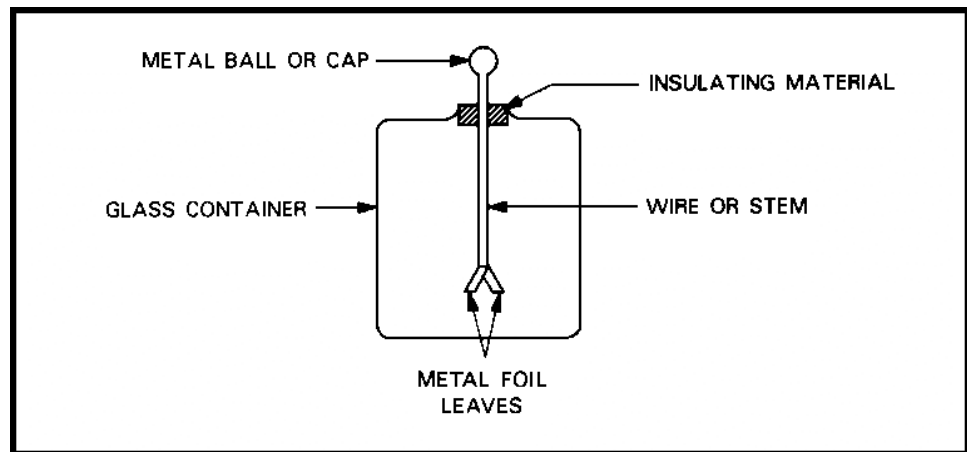

Figure 1-7. Electroscope.

MM0703, Lesson 1

If the ball receives either a positive or a negative charge, it causes the leaves to spread apart. The leaves spread because like charges repel. When a charge of positive electricity is placed on the leaves, the spread of the leaves will increase when the ball is approached by a positively charged body. On the other hand, a negatively charged body brought near the ball or cap will decrease the spread.

You can place a charge on the leaves by bringing a charged body near, but without making physical contact with, the ball. This is charging by induction. As soon as you remove the charged body, the electroscope is no longer charged unless you provided some means for it to gain or to lose some electrons while the charge was being induced. You can do this by connecting a wire from the electroscope to some neutral conducting object, such as ground. Then, if a charged body is brought near the electroscope, electrons can leave if the charge is negative or enter if the charge is positive. If the wire is disconnected before the charged body is removed, the electroscope will remain charged oppositely to the charge that induced it. This is charging by conduction because the electroscope comes into direct contact with the charged body.

Conductors and Insulators

With certain materials, electrons can be quite readily separated from the atom. In fact, there is much evidence to show that in some metals there are free electrons. Experiments show either that free electrons unattached to atoms do exist or that there is a free interchange of orbital electrons between adjacent atoms. The effect is the same: at any instant, the metal seems full of free electrons. Such material, called a conductor, offers little opposition to the movement of electrons between atoms. While, in general, all metals are good conductors, silver, gold, copper, and aluminum are particularly good.

Materials (such as rubber, glass, silk, fur, mica, and air) which have few free electrons are classed as insulators. Such materials offer great opposition to the movement of electrons between atoms. Materials mentioned previously, on which a charge can be placed by rubbing with a dissimilar material, are insulators. If the center of a long rubber rod is rubbed with a piece of fur, an excess of electrons will locate in the rod's center instead of spreading immediately over the whole surface of the rod.

If, on the other hand, an excess of electrons could be placed at a point on a conductor of uniform cross section, they would immediately spread evenly over the entire surface of the conductor because of the free movement of the electrons.

Since all materials, to some extent, both permit and oppose the movement of electrons, there is no such thing as a perfect conductor or a perfect insulator. Even though there is no sharp dividing line between conductors and insulators, only good conductors are used as conductors and only good insulators are used as insulators.

Distribution of Charges on Objects

The surface density of a charge on an object depends upon the shape of the object (figure 1-8). If you were to touch the charged object with a proof plane (a tiny metal plate with an insulated handle), it would remove part of the charge of the object. If you were then to bring the proof plane in contact with an electroscope, the rise of the electroscope's gold leaves could be taken as a measure

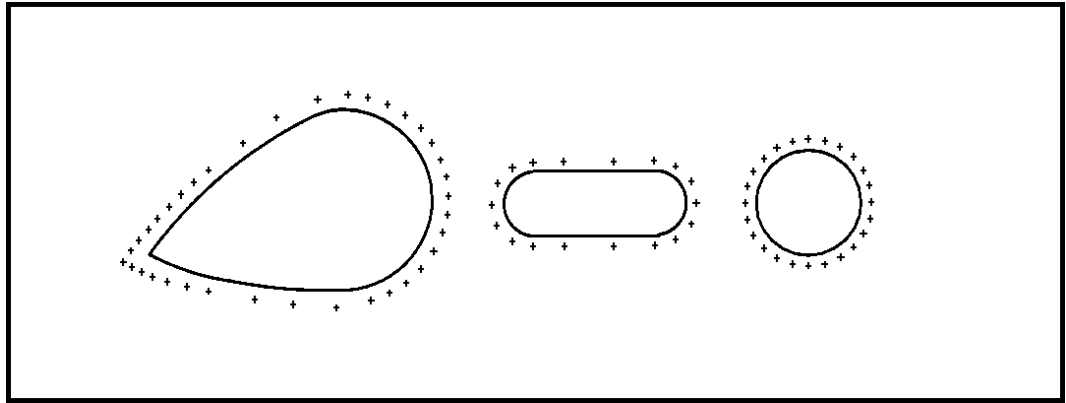

Figure 1-8. Distribution of Charges on Different Shaped Objects.

of the charge on the plane, and hence, the charge density of the object. In this way, you would find that the density of the charge on the outside of a sphere is uniformly distributed. On charged objects other than spheres, the greatest density of charge is found on the part which has the greatest curvature or sharpest point. Thus, if a tear-drop-shaped object were charged, the intensity of the electric field would be greatest in the region of the sharp point. The sharper the point, the lower the breakdown voltage for a given separation and the sooner a spark will jump across the gap. That's why lightning rods and some spark gaps are shaped the way they are.

Electrostatic Shielding

If you were to take a hollow spherical conductor with a hole in it, you would find that, regardless of the amount of charge on the outer surface, there would be no charge on the inner surface. You could prove this statement by inserting a proof plane into the charged sphere, making contact with the inner surface, removing the proof plane, and testing it with an electroscope. If any charge were present on the inner surface, a part of it would be transferred to the proof plane and the electroscope would show the presence of the charge. This experiment has always shown no measurable charge.

This property of a closed conductor is the basis of electrostatic shielding, that is, enclosing circuit elements in metal cans to isolate them from outside electric fields.

MAGNETISM

There are important relationships between the laws of magnetism and the laws of electrical currents. Generation and transmission of large amounts of electrical energy on an economical basis is one of the most practical of these relationships. A high-speed digital computer is also an example, as well as the meter that measures the amount of electrical power used in your home. Since magnetism is so important to the field of electricity, you need to be familiar with its principles.

History and Definition

The knowledge of magnetism is very old. The early Greeks knew that certain stones (lodestones), found in the district of Magnesia in Asia Minor, had the apparent magic property of attracting small bits of iron. The reason was the ore in these stones, Fe_3O_4 , called magnetite for the region magnesia. Soon any substance that possessed the property of attracting bits of iron was called a magnet. Attracted substances are known as magnetic substances. The phenomenon associated with magnets and magnetic materials is known as magnetism.

Magnets can also be man-made. You do it by stroking a steel bar with one end of a lodestone or a magnet or by placing a steel bar in a coil of wire through which an electric current is passed.

Forces Between Poles

If iron filings were sprinkled over a permanent magnet, the greatest concentration of filings would be seen near the end of the magnet (as shown in figure 1-9) with practically none near the center. The regions near the ends of the bar are called the poles of the magnet, and the line joining the two poles is known as the magnet's magnetic axis.

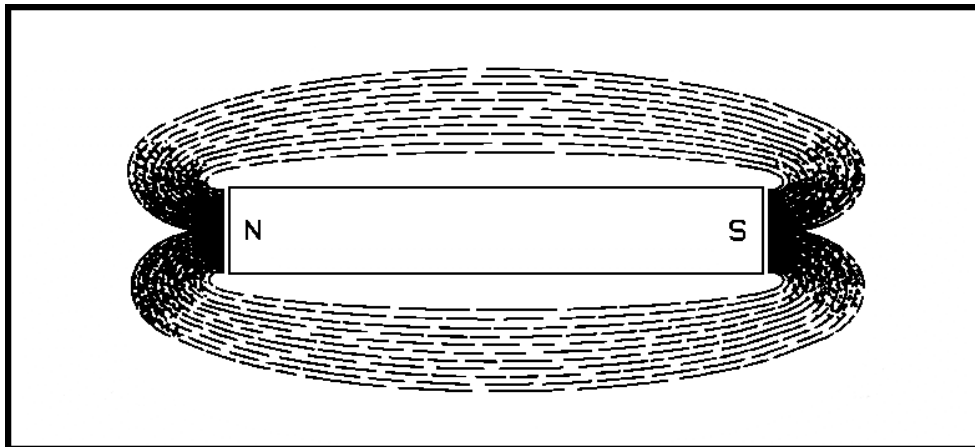

Figure 1-9. Poles of a Magnet.

If a bar is suspended horizontally by a string or mounted on a pivot, it will line up in roughly a north-south direction. Because one end of the bar magnet will always point north, the pole that tends to seek the magnetic north is called the north pole (N). The other, which tends to seek the magnetic south, is called the south pole (S). Thus, the ends of all bar magnets may be marked as north poles or south poles.

Also, if you mounted bar magnets on pivots (figure 1-10) so that they were free to move, you would find that like poles of two magnets would repel each other, whereas unlike poles would attract each other. By using long, slender, magnetized needles, the north and south poles would be sufficiently separated from each other so that the magnitude of the forces between individual poles could be measured. This was first done by the French physicist Charles A. Coulomb in 1785. By suspending a long needle from a brass wire attached to a graduated

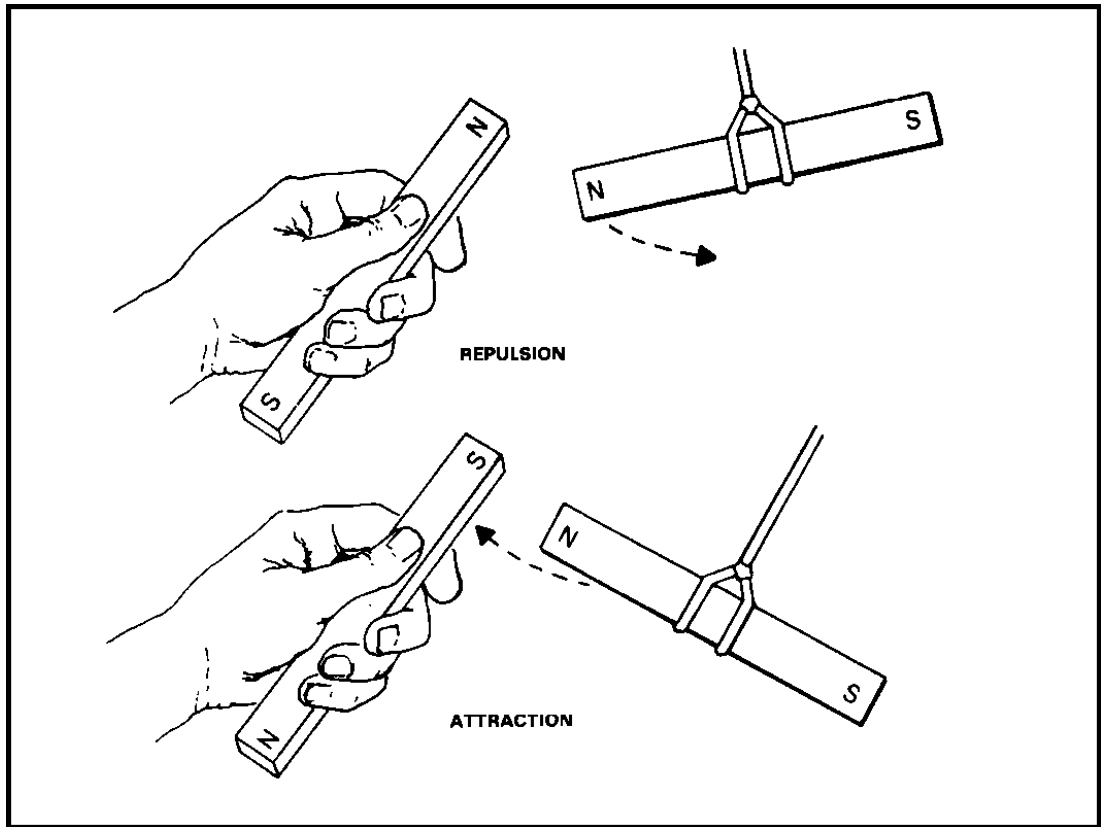

Figure 1-10. Repulsion and Attraction of Poles.

scale, he was able to determine how much mechanical torque had to be applied to hold the needle in its zero position when another long magnetic needle was brought near it. Coulomb determined that the force of repulsion between two north poles was inversely proportional to the square of the distance between them. By experimenting with various magnets, he was able to demonstrate that different magnets, when at the same distance, from the suspended magnet, produced different forces. He was able to assign to each magnet a definite pole strength, relative to a standard magnet. He then expressed the results of his investigation as:

$$F = \frac{1}{\mu} \times \frac{m_1 m_2}{d^2} = \frac{m_1 m_2}{\mu d^2}$$

where m_1 and m_2 are the strengths of the poles of the two magnets, d is the distance between poles, and μ a constant, which depends mainly on the medium between the poles. The quantity μ is called the permeability of the medium. When the medium is air, μ is usually considered to be 1. Therefore, μ is left out of the calculations and the formula resolves to:

$$F = \frac{m_1 m_2}{d^2}$$

MM0703, Lesson 1

As an illustration, compare the forces acting on two bar magnets 15 cm long with their north poles 10 cm apart as shown in figure 1-11. Assume the pole strength of each magnet to be 400 units.

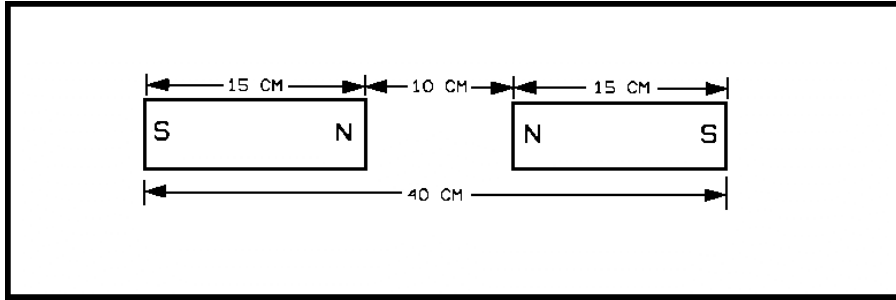

Figure 1-11. Forces of Repulsion and Attraction.

Solution:

Force of repulsion between north poles equals

$$\frac{(400)(400)}{(10)^2} = 1,600 \text{ dynes.}$$

Magnetic Fields

Characteristics. From the preceding discussion, you have seen that forces act on bar magnets and magnetic materials brought into the surrounding region of another bar magnet. Remember this as you learn the concept of a magnetic field, which is a region wherein magnetic forces act.

A magnetic field surrounds a bar magnet and permeates it. You can see this by placing a glass plate over a bar magnet and sprinkling iron filings on the glass. By tapping the glass, the iron filings will align themselves with the field and will form chains between the north and south poles of the magnet. The chains, referred to as magnetic lines of force, are lines indicating the direction along which a small magnetic compass tends to align itself. Also, it can be seen that the concentrations of iron filings are greatest where the magnetic field is most intense. They have a definite direction and may be thought of as leaving the north pole and reentering the south pole, and then continuing through the magnet from the south pole to the north pole as shown in figure 1-12.

Another interesting effect appears when other magnets are brought into the magnetic field of the first magnet. The alignment of iron filings along the magnetic lines of force between various magnetic pole combinations is shown in figure 1-13.

Although magnetic lines of force are intangible, they have the following six properties:

1. They are continuous and always form closed loops.
2. They have a tension (along the direction of the lines) which tends to shorten them. Thus, when two unlike poles are brought near each other, the lines of force existing between them are brought closer together.

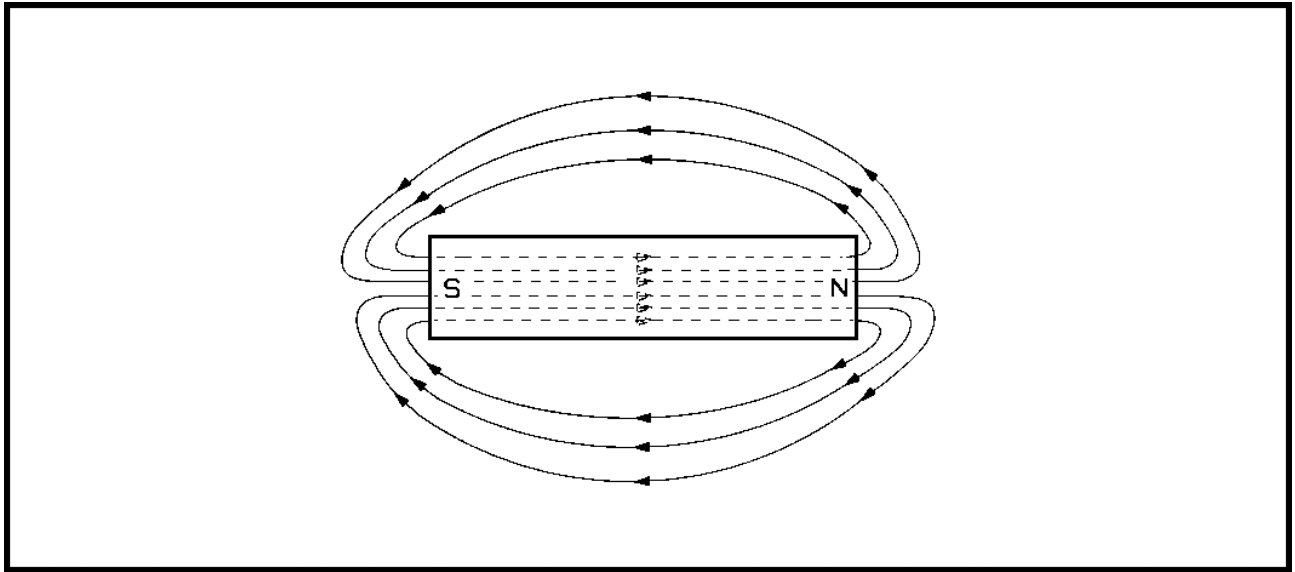

Figure 1-12. Magnetic Field About a Bar Magnet.

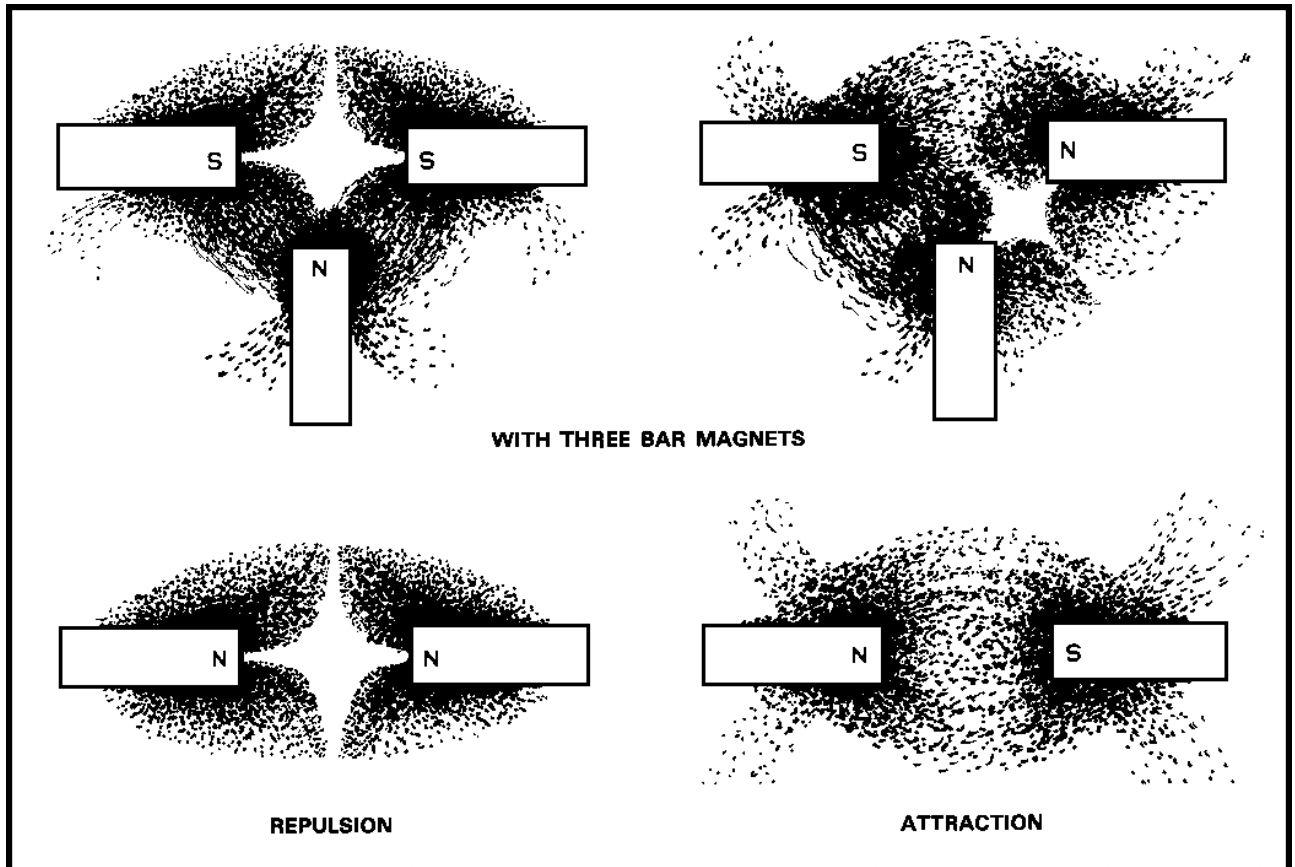

Figure 1-13. Shapes of Magnetic Fields.

MM0703, Lesson 1

3. They never cross one another.
4. They are conducted by all materials.
5. When from like poles, they tend to push one another apart when the poles are brought near each other.
6. They concentrate in magnetic materials.

Strength of Magnetic Fields. If you place a magnetic pole of strength in a magnetic field, then from the definition of a magnetic field, a force will act upon the pole. The magnitude and direction of this force will vary from point to point, which means that the magnetic field must have a definite direction and magnitude at each point in space. The direction of a magnetic field is that of the force acting upon an isolated north pole.

The intensity of the magnetic field at any point is defined as the force that would be exerted upon a unit north pole if situated at that point. The intensity of a magnetic field in which a unit magnetic pole experiences a force of one dyne is defined as an oersted (after Hans C. Oersted, a Danish physicist). From this definition, if at any point in a magnetic field a pole strength of M units has a force of F dynes acting upon it, the field intensity H at that point in oersteds will be:

$$H = \frac{F}{M} \text{ oersteds.}$$

Thus, if an isolated pole of 40 units strength, placed at some point in a magnetic field, is acted upon by a force of 240 dynes, the field intensity at that point is:

$$H = \frac{F}{M} = \frac{240}{40} = 6 \text{ oersteds.}$$

Flux density is a measure of the lines of force per unit of area. The unit of flux density, represented by a letter B , is the gauss. One line of force is known as a maxwell. One maxwell per square centimeter represents a flux density of one gauss. All of these terms will occur again in your study of electricity.

Terrestrial Magnetism

A suspended magnet, in orienting itself in a particular direction at every point on or near the earth, shows that the earth is surrounded by a magnetic field. You could think of the distribution of this field as being produced by a huge bar magnet within the earth, located about 17ϕ away from the earth's axis and having a length much less than the earth's diameter. See figure 1-14.

Since the magnetic pole is away from the geographic north pole, the compass will not point true north (geographic north) over most of the earth's surface. The angle the compass makes with the geographical meridian is called the variation of the compass (declination).

The direction of the earth's magnetic field is not horizontal, except at the magnetic equator, as you could see if you balanced a magnetized needle on a horizontal spindle. This angle between the magnetized needle and the horizontal is called the inclination or angle of dip. The angle of dip increases from zero at the magnetic equator to 90° at the magnetic poles.

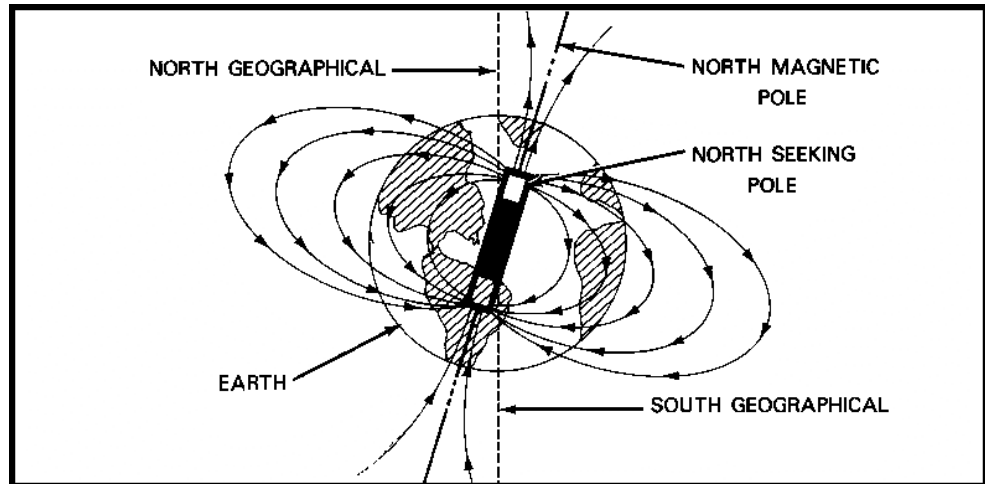

Figure 1-14. Earth's Magnetic Field.

The earth's magnetic field does not remain the same year after year. There are daily, annual, and secular (a period of 960 years) changes. Much work has been done in attempting to explain terrestrial magnetism, but too little is known about the magnetic sources within the earth and atmospheric currents to establish a satisfactory theory of the earth's magnetism.

Theory of Permanent Magnets

If you took a piece of unmagnetized steel and stroked it with a magnet, it would become a permanent magnet. Careful investigation of the process would reveal that no material had been transferred to the bar of steel. The effect apparently takes place upon something already in the steel bar.

Again, if we took a magnetized steel bar and cut it in two pieces, we would then have two magnets (see figure 1-15), and if the process were continued until molecular dimensions were approached, each resulting particle would be a magnet.

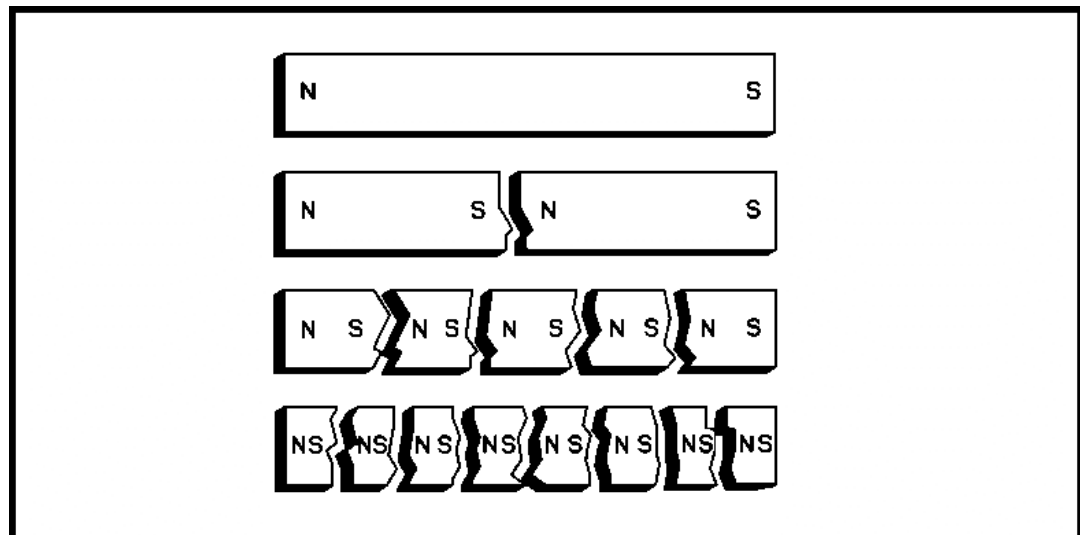

Figure 1-15. Permanent Magnets Showing Continuity of Polarity.

MM0703, Lesson 1

From this you should be able to assume a working hypothesis that the steel bar, even in its unmagnetized condition, possesses magnetic particles of molecular dimensions distributed throughout the bar randomly. The presence of a magnetic field has the effect of aligning these magnetic particles. This is illustrated in figure 1-16 where you can see the difference between an unmagnetized bar, and a permanent magnet. That poles of a magnet are surface effects reflecting internal conditions is called the molecular theory of magnetism. Recent experimental work in atomic structure assigns the magnetic properties of iron to a large magnetic domain within the atom.

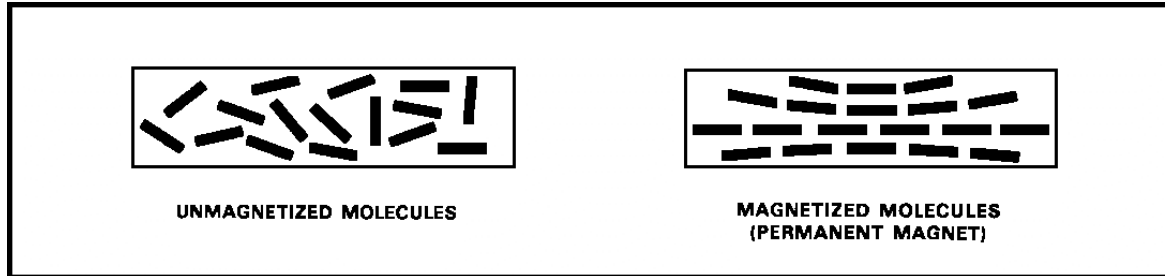

Figure 1-16. Molecular Theory of Magnetism.

Two other terms commonly used in the discussion of magnetic theory are permeability, which is a measure of the relative ease with which magnetic lines of force travel within a material, and reluctance, which is the property of a medium to resist the passing of lines of force. Reluctance corresponds to resistance in an electrodynamic circuit.

Electromagnetism

The discovery by Hans C. Oersted in 1820, that a compass needle is deflected when placed near an electric current was of fundamental importance in that it immediately suggested a connection between electricity and magnetism. The magnet (needle) returned to its original position as soon as the current was zero, or the needle was deflected in the opposite direction if the current was reversed. Since, by definition, a magnetic field is a region where forces act on magnets, you can imply that a magnetic field surrounds the current-carrying conductor. The magnetic field may be represented by line of force as previously mentioned. As with permanent magnets, you can indicate the nature of the field about any shaped conductor with iron filings.

By exploring the field around a very long conductor with a tiny compass needle, you will find that the lines of force are circles with their centers in the wire (see figure 1-17A). A convenient method of remembering the direction of the field about a wire is to recall the left-hand rule. If you mentally grasp the wire with the left hand, holding the extended thumb in the direction of the electron flow, your fingers circle the wire in the direction of the magnetic field.

The polarity of a coil can also be determined by the left-hand rule. Grasp the coil in the left hand so that the fingers follow the direction in which current is flowing. The thumb will point to the north pole (see figure 1-17B). In the case of a circular loop carrying a current, the flux lines are shown as in figure 1-18.

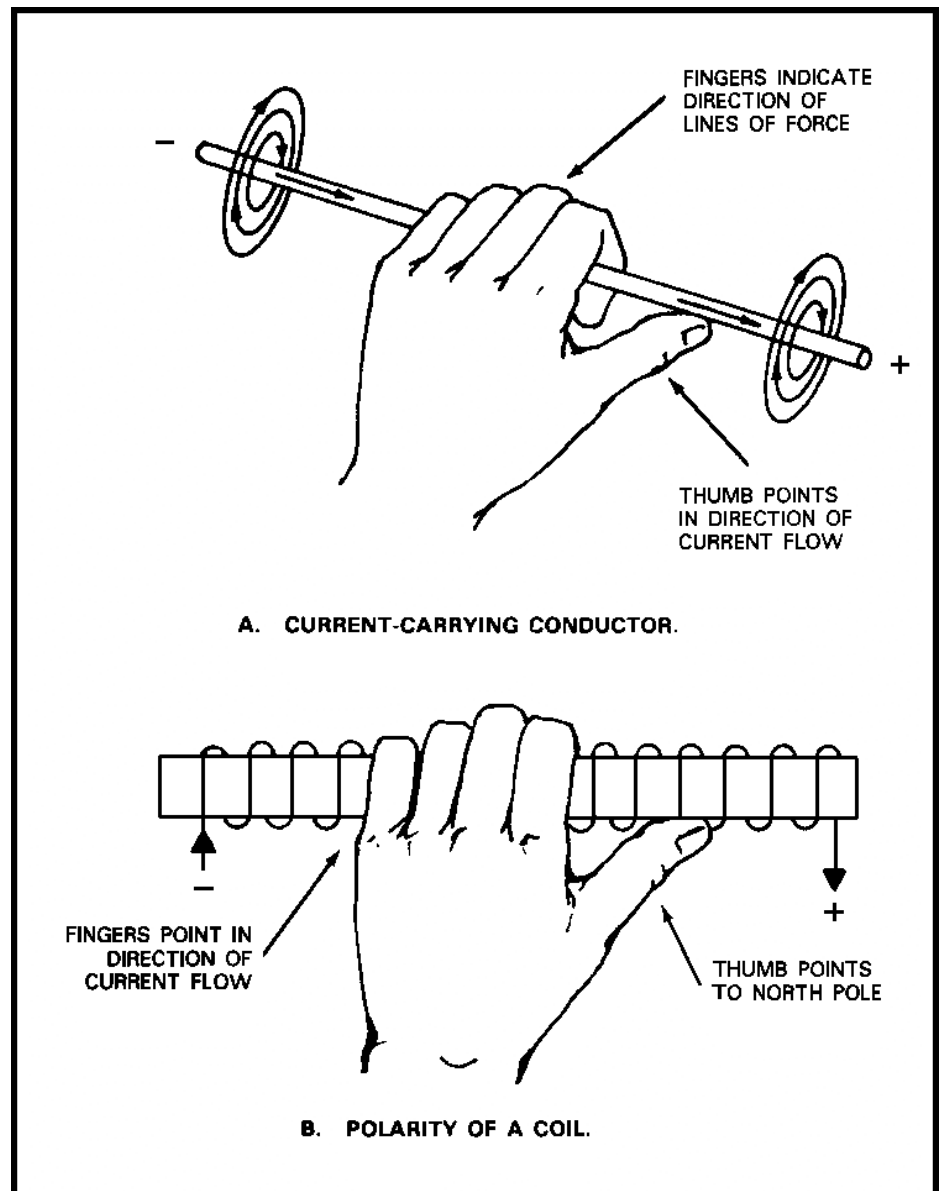

Figure 1-17. Left-Hand Rule for Magnetic Fields.

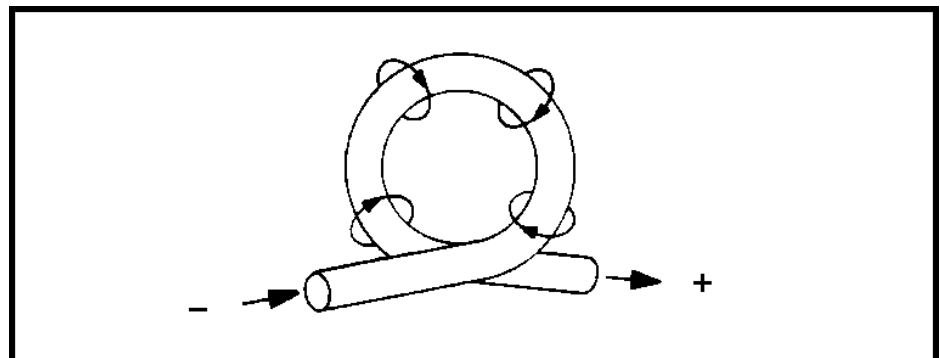

Figure 1-18. Direction of Flux in a Circular Loop.

MM0703, Lesson 1

The magnetic field of a solenoid is shown in figure 1-19. A solenoid can be made by winding an insulated wire on a cylinder. On exploring the field, either by a compass needle or with iron filings, you will find that the field is quite uniform at the center but, near the ends, the lines of force diverge. Each line of force, however, is a closed loop. The similarity between the field produced by a solenoid and that of a permanent magnet is striking. In fact, a permanent magnet can be replaced by a suitable solenoid as far as exterior magnetic effects are concerned. The best material for solenoids used to make electromagnets is soft iron.

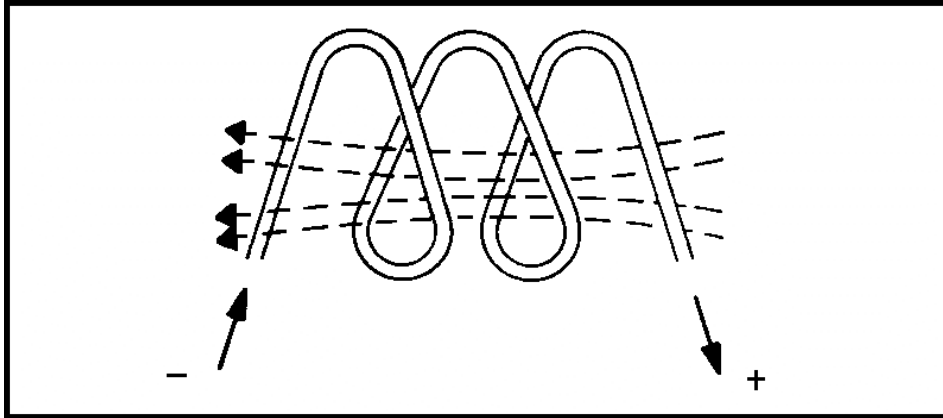

Figure 1-19. Magnetic Field in a Solenoid.

On the basis of experimental data, the following important generalization can be made: *Regardless of its origin, a charge in motion will invariably give rise to a magnetic field.*

In the discussion of permanent magnets, you learned that the force between magnets was from an interaction between their fields. Hence, if a current has its own magnetic field, there will be a force acting on a conductor carrying a current when it is placed in a magnetic field. This can be illustrated by the following experiment. A solenoid is freely suspended as shown in figure 1-20. A magnet is hung near one end of the solenoid. The magnet is held rigidly, and a current is sent through the solenoid. The solenoid moves toward the magnet. If the current through the solenoid is reversed, the solenoid moves away from the magnet. A force is acting on a conductor carrying current when placed in a magnetic field.

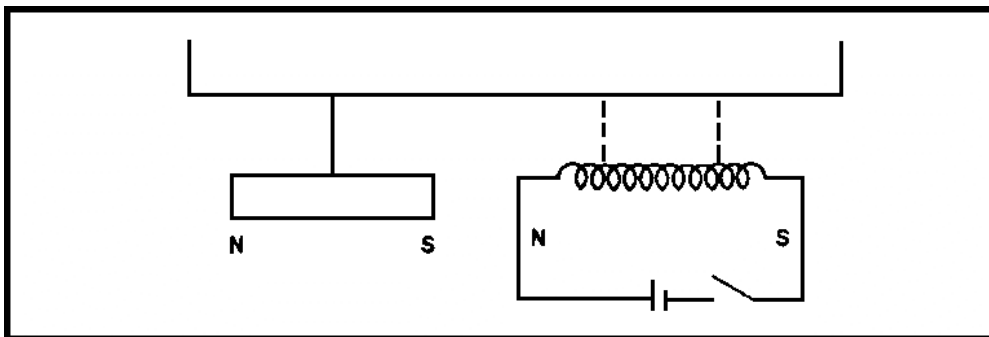

Figure 1-20. Solenoid in a Magnetic Field.

Figure 1-21A shows a useful way for determining the direction of the force exerted on a current-carrying conductor in a magnetic field. Figure 1-21B indicates a current flowing toward you, out of the paper, with its associated magnetic field, superimposed upon a uniform magnetic field. Figure 1-21C shows the effect of the two magnetic fields upon each other. Since the two fields are traveling in the same direction on the left, the resultant field is strengthened. On the right, the two fields are opposing each other and the resultant field is weak-ended. In this case, the net effect is that the conductor will tend to move toward the weaker part of the field.

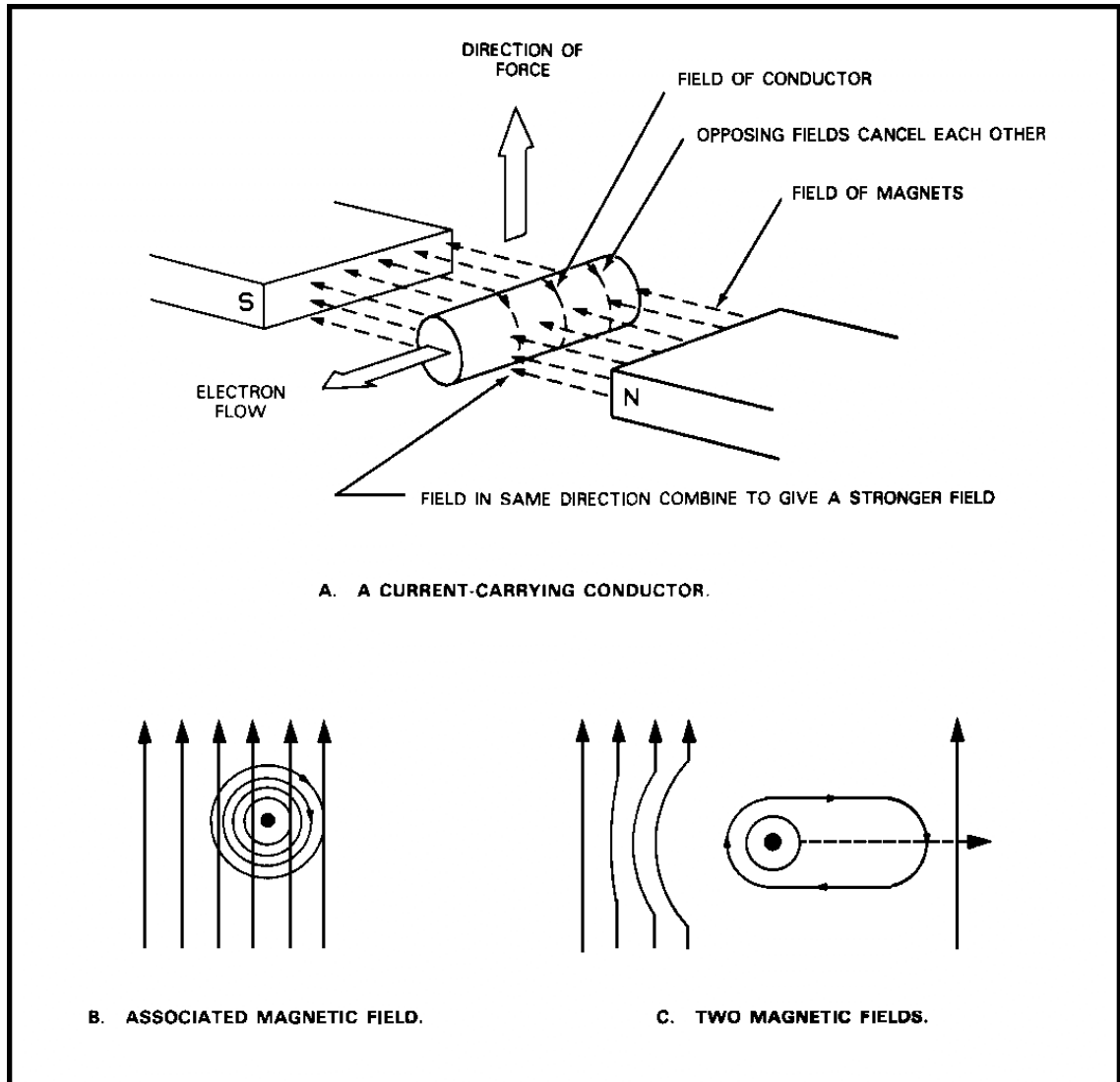

Figure 1-21. Force on a Conductor in a Magnetic Field.

MM0703, Lesson 1

Two parallel current-carrying conductors are shown in figure 1-22. The direction of the magnetic lines of force is given by the left-hand rule. If the currents are in the same direction, the two fields cancel in the area between the two conductors. The conductors tend to move in the direction of the weaker magnetic field, and there is attraction between the wires. If the currents are in opposite directions, the two fields add between the wires. The conductors tend to move in the direction of the weaker magnetic field, and there is repulsion.

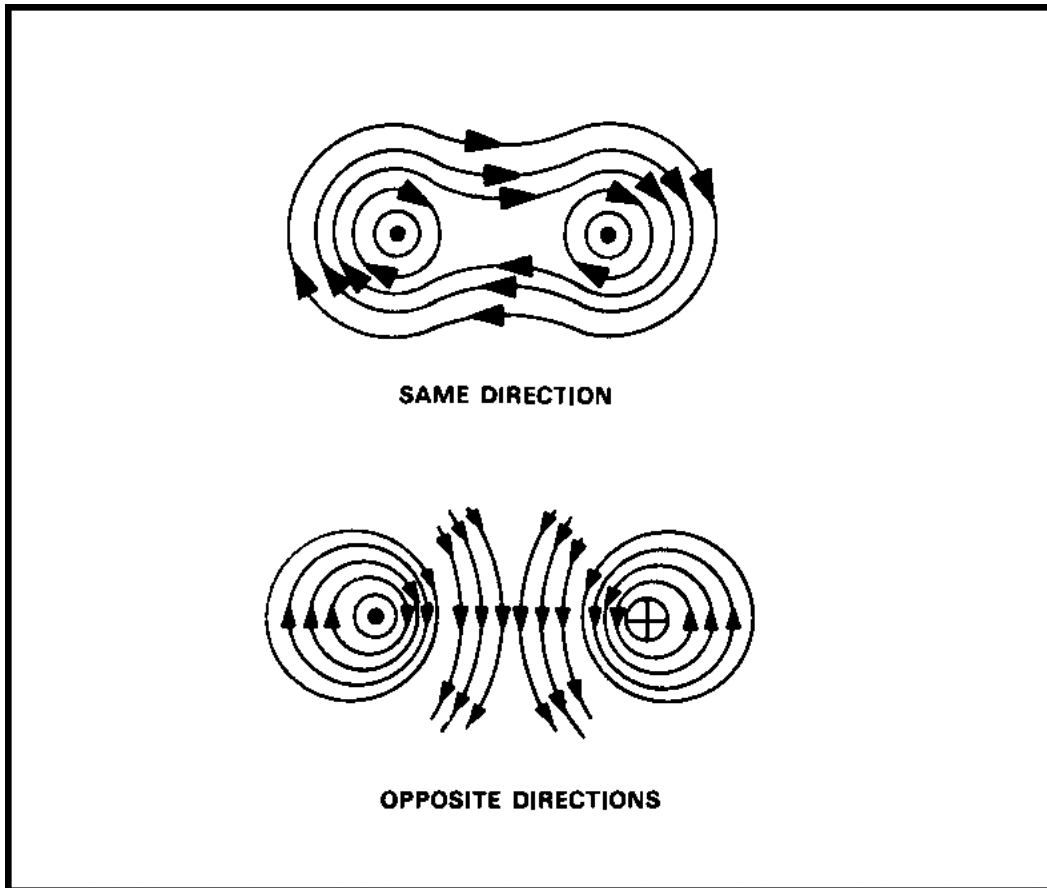

Figure 1-22. Fields Surrounding Two Adjacent Conductors.

If a conductor is forced to move through a magnetic field, a current is produced in the conductor. There is an easy way to determine the direction of this induced current. Figure 1-23 shows the relationship between the direction of a magnetic field, the direction of motion of a conductor, and the direction on the induced current. It is called the left-hand rule for induced current.

From the foregoing, the following rules can be formulated:

- Conductors carrying current in the same direction tend to be drawn together; conductors carrying current in opposite directions tend to be repelled from one another.
- All electric circuits tend to take a position that will make their currents parallel and flow in the same direction.

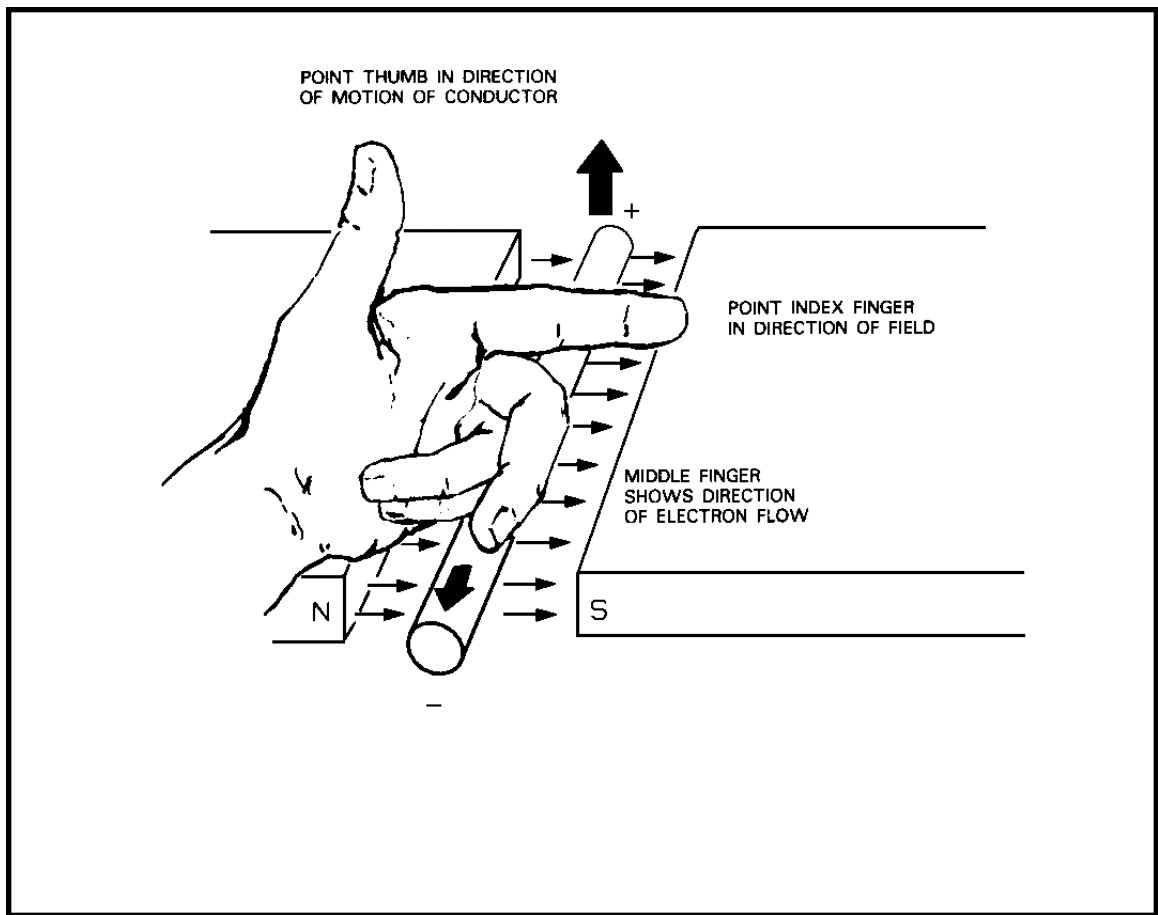

Figure 1-23. The Left-Hand Rule for Induced Current.