

FF-CAD

Operations Manual

Digital Audio Delay Module for
Repeater Systems



P.O. Box 5533
Round Rock, TX 78683
512-365-1120 (voice)

"AFFORDABLE REPEATER CONTROL SOLUTIONS"

FF-CAD - Codec Audio Delay Rev 2.01 (PCB rev S)

Table of Contents

Warranty.....	1
FF-CAD Specifications	2
Introduction.....	3
FF-CAD Operation	3
Installation.....	5
Setting Delay Time.....	6
Optional DTMF Decoder.....	6
Receiver COS Connection.....	7
APPENDIX A FF-CAD Cable preparation	8
APPENDIX B Connection to an FF-800 repeater.....	9
APPENDIX C PTT Hang Time Option	12
APPENDIX D Parts list and schematic.....	13

Warranty

FF Systems warrants its products to be free from defects for one year from the date of shipment. FF Systems may opt to repair or replace (at our option) any defective product. FF Systems does not warrant any defect due to lightning or other natural disaster. Any user modifications or repairs to any product sold by FF Systems will void this warranty. All returns must be accompanied by a Return Material Authorization (RMA) number provided by FF Systems prior to shipment. Shipments that do not have the proper return authorization prominently noted on the outside of the package will not be accepted. The purchaser is responsible for all shipping charges for any service procedure(s) performed by FF Systems (including warranty service).

30 Day Money Back Guarantee

FF Systems offers a 30 day trial period on all products. The 30 day trial begins 5 calendar days after shipment from FF Systems. If the purchaser decides to return a product they must contact FF Systems for a Return Material Authorization (RMA) number on or before 6:00pm central time within 35 calendar days of the original shipment date. The purchaser then has fourteen additional days to return the merchandise to FF Systems. FF Systems claims no liability for lost or mis-directed shipments. The purchaser is responsible for all shipping charges.

Product Condition

Products must be in new condition or warranty repairable to qualify for refund. If merchandise incurs damage not covered under warranty, the refund will be delayed until the unit has been repaired and the cost of that repair shall be deducted from the refund. FF Systems is not responsible for damages incurred during shipment -- the purchaser should insure the merchandise for the purchase amount to avoid possible loss due to damage during shipment.

Contact Address

FF Systems
P.O. Box 5533
Round Rock, TX 78683
512-365-1120 (voice)

email: joeh@rollanet.org
web: <http://www.rollanet.org/~joeh/>

FF-CAD Specifications

Power requirement +8.5 to +14.5 volts @ 50 mA
Power input features over-voltage and reverse polarity protection.

Digital signals:	MUTE1, Delay Inhibit MUTE2	0 - 5V 0 - 40V
Analog signals:	Usable audio input level Input and Output Coupling Input impedance Audio Output level Audio Output impedance Output noise floor Intermod Distortion Passband flatness (200hz-3khz)	50 mV _{rms} (min) to 3.0 V _{rms} (max) AC 100 K Ω (50K Ω w/ DTMF option) tracks input level Less than 1K Ω -69 dbV (0.3 mV) better than -50 db +/- 0.5 db
Board dimensions		4.0" x 3.0"
Maximum delay	Factory standard With extended memory option	1000 msec 4000 msec

Units:
0 dbV = 1 V
1 V_{rms} = 0.354 V_{pp}

Introduction

The FF-CAD is a microprocessor controlled audio delay module that uses a codec for A/D and D/A operations. The audio processing and delay is all digital which results in high fidelity audio reproduction for all values of delay time. Because the audio quality is not dependent on delay time, very long delays are possible -- depending on the size of the delay memory, up to 4 seconds of delay are possible. In addition, there are provisions for muting incoming audio for valid DTMF signals, and a separate muting input can be used to mute the audio when a receiver COS drops. This allows the FF-CAD to independently handle all functions required to "clean up" DTMF signals and loss of COS noise bursts -- other delay modules require the host repeater controller to perform these muting functions. Of course, the FF-CAD also works very well with any controller which supports other popular delay modules.

FF-CAD Operation

The FF-CAD features an 8-bit audio codec which applies μ Law (pronounced "mue-law") compression to audio samples. This compression scheme results in improved dynamic range over linear A/D conversion. The sample frequency is 8.0 KHz which allows the codec to faithfully reproduce incoming signals up to 3 KHz. The incoming audio samples are stored in a memory buffer which represents the delay medium for the audio. There are three sizes of memories that are supported by the FF-CAD (selected by J2/3): 2K byte (250 ms maximum delay), 8K byte (factory standard: 1 sec maximum delay), and 32K byte (4 sec maximum delay).

While the maximum delay is determined by the memory device, the actual delay step size is determined by two cut jumpers on the bottom side of the FF-CAD PC board. The factory default is for both jumpers to be shorted. One or both may be cut with a razor knife or similar instrument to select a different delay size. Table 1 describes how the jumper settings relate to delay size. "Minimum Memory Size" refers to the minimum size required for a given delay setting.

<u>delay step</u>	<u>CJ2</u>	<u>CJ1</u>	<u>Minimum Memory Size</u>
15ms	short	short	2K
30ms	short	open	8K
60ms	open	short	8K
240ms	open	open	32K

PCB legend: CJ1 = "1", CJ2 = "2". Jumpers are located on the solder side under U1.

Table 1. Delay step settings.

The 16 position rotary switch (SW1) is used to set the delay value resulting in 16 distinct delay settings -- a binary value for the delay setting can also be supplied from an external source which allows the user the option of remotely changing the delay settings. Table 2 illustrates the delay times for each of the four supported delay step sizes.

#	DELAY sw <u>setting</u>	*Ext inputs <u>3210</u>	Delay for each step size (ms)			
			<u>15ms</u>	<u>30ms</u>	<u>60ms</u>	<u>240ms</u>
00	0	0000	15.6	31.2	62.4	249.6
01	1	0001	31.3	62.6	125.2	500.8
02	2	0010	46.9	93.8	187.6	750.4
03	3	0011	62.5	125.0	250.0	1000.0
04	4	0100	78.1	156.2	312.4	1249.6
05	5	0101	93.7	187.4	374.8	1499.2
06	6	0110	109.4	218.8	437.6	1750.4
07	7	0111	125.0	250.0	500.0	2000.0
08	8	1000	140.6	281.2	562.4	2249.6
09	9	1001	156.3	312.6	625.2	2500.8
10	A	1010	171.9	343.8	687.6	2750.4
11	B	1011	187.5	375.0	750.0	3000.0
12	C	1100	203.1	406.2	812.4	3249.6
13	D	1101	218.8	437.6	875.2	3500.8
14	E	1110	234.4	468.8	937.6	3750.4
15	F	1111	250.0	500.0	1000.0	4000.0

* See text

Table 2. Delay time settings.

In addition to the delay function, there are several logic inputs which control the audio output -- these logic signals set the FF-CAD apart from other audio delay modules because they allow the FF-CAD to perform all features that an audio delay module is typically used for. The DTMF mute input, MUTE1, mutes the audio output when a high level logic signal is applied. However, after the logic signal goes low, the FF-CAD continues to mute the audio output for a period of time equal to the current delay setting. This eliminates the DTMF "blip" that occurs when muting is applied without delay. The DTMF mute input is intended to accept a data valid signal from an external DTMF receiver -- however, the FF-CAD has a provision for an on-board DTMF receiver which can supply the data valid signal without the external connection. The MUTE1 input allows the FF-CAD to be used with any repeater controller that does not directly support an audio delay module.

A separate mute input, MUTE2, is provided for connecting a receiver COS signal. This mute input behaves differently from the DTMF mute input in that there is no delay applied to the mute function. When the input is low, the audio output of the FF-CAD is immediately muted -- when the input goes high, the audio output is immediately passed. This feature allows the elimination of the "bump" or noise burst which occurs when the squelch closes on most receivers.

A third signal, ~DLYINH, is provided to suppress the delay operation. When this input is brought low, the audio output follows the input with no delay -- a high or open input returns the delay operation. This provides the user with the ability to easily eliminate the delay operation with a simple logic signal.

Installation

The basic connection of the FF-CAD is accomplished through a four pin cable that is supplied. The logic inputs are connected through a 9 pin Molex type connector. The following list describes the connector pinouts along with a signal description for each: ~ = Active low signal

P1: Delay I/O (molex 4 pin)	P2: Logic inputs (molex 9 pin)
1) Audio In	1) Ext. Delay [0]
2) Audio Out	2) Ext. Delay [1]
3) GND	3) Ext. Delay [2]
4) +12V	4) Ext. Delay [3]
	5) PTTout (opt)
	6) MUTE1 (opt PTTin)
	7) MUTE2
	8) ~DLYINH
	9) GND

Audio In/Out:

{**P1-1**: Audio in} This is the Audio input to the delay module. It accepts inputs up to 3 V_{rms} and has an input impedance of 100K Ω (50K Ω with the DTMF option).

{**P1-2**: Audio out} This is the Audio output from the delay module. The output level tracks the input level and has an output impedance of about 300 Ω .

{**P1-3**: GND}

{**P1-4**: DVR out} +12V input. The FF-CAD may be operated with a power input from +8.5 to +14.5 volts. The FF-CAD draws less than 50 mA of current.

NOTE: For best S/N ratio, the audio input to the FF-CAD should be as close to 3 V_{rms} as possible. The codec will track the input down to as low as 50 m V_{rms} , but the best output signal is obtained with maximum input.

Logic Inputs:

{**P2-1 - P2-4**: DELAY[3:0]} These four inputs comprise the binary value for the current delay setting. If an external source is used to set the delay, the user should set the on-board rotary switch to position "0" -- if the rotary switch is to be used, these pins should be left unconnected.

{**P2-6**: MUTE1} DTMF data valid input. When high, this input mutes the output of the FF-CAD. The mute operation continues after this input goes low until the delay time has elapsed.

{**P2-7**: MUTE2} General mute input. When high, this input mutes the output of the FF-CAD. There is no delay applied to the falling edge of this input.

{**P2-8**: ~DLYINH} General mute input. When high (or not connected), the FF-CAD operates normally and applies the current delay setting to the audio. When this signal is brought low, the delay operation is suspended and all audio is passed without delay. While delay is suspended, the FF-CAD will still store data to the memory such that when the delay is resumed, the delayed audio will immediately active from the memory.

{**P2-9**: GND}

The FF-CAD should be placed in the same enclosure as the repeater controller or other interface to which it is to be connected. If the FF-CAD must be located in another enclosure, use shielded cable and keep the connection as short as possible.

Setting Delay Time

As was discussed in the FF-CAD Operation section, the delay time is set by either the 16 position rotary switch (DELAY, SW1) or the external 4-bit delay input. The delay setting can be changed at any time and the FF-CAD automatically updates the delay time when the switch setting or external inputs are changed.

The connection to the external delay inputs must be active high and should use open collector or open drain drivers (these drivers conduct to ground for logic "0" and float for logic "1"). For proper operation with external delay inputs, the DELAY switch must be set to position "0" and J1 must be changed for open collector/drain drivers. The J1 (-) to J1 (center) connection is broken and J1(+) is connected to J1(center) (J1 is located near the DELAY switch, refer to the parts layout in appendix C). This sets the inputs for pull-up operation (required for open collector/drain drivers). If the delay setting inputs are driven from push-pull logic (i.e., CMOS gates), the J1 setting is irrelevant.

Optional DTMF Decoder

The DTMF decoder option allows the FF-CAD to automatically remove DTMF "blips" from the delayed audio. This option consists of a DTMF receiver which is connected to the MUTE1 input of the microcontroller I.C.. This option **should not** be used when connecting the FF-CAD to a controller which already supports audio delay. The reason for this relates to the DTMF un-mute features that most controllers have. With the FF-CAD in-line and the DTMF option installed, there is no direct way to utilize the DTMF un-mute feature to pass DTMF tones to the repeater output.

Another problem with using the DTMF option arises when the FF-CAD is placed in the receiver audio before it gets to the controller. In this case there is no way for the controller to receive DTMF signals because the FF-CAD mutes them before they get to the controller's input. It is important that the FF-CAD be inserted in the audio path AFTER the controller taps the audio for its DTMF receiver.

NOTE:

If the FF-CAD has the DTMF option and it is to be used with a controller that supports audio delay, the user should perform the following to disable the DTMF receiver:

- remove the DTMF receiver chip (U8, M8870-1).
- carefully bend out pin 15 about 45° so that it won't make contact with the socket pin.
- re-install the DTMF receiver chip at U8.

If U8 is soldered without a socket, then it may be disabled by removing R14 (100KΩ 1/4W resistor near U8).

The DTMF option may be factory installed, or the decoder may be installed by the user using components obtained separately. For those who choose to field install the option, the following components are required:

<u>QTY</u>	<u>Desig.</u>	<u>Description</u>	<u>QTY</u>	<u>Desig.</u>	<u>Description</u>
1	U8	M8870-1 DTMF receiver	1	C18	0.1 μF, 50V ceramic capacitor
1	U8	18 pin DIP socket (optional)	1	C19	470 pF, 50V ceramic capacitor
1	R7	2.4KΩ, 1/4W resistor, 5%	1	C20	10μF, 25V electrolytic capacitor
1	R14	100KΩ, 1/4W resistor, 5%	1	C21	0.1μF, 50V ceramic capacitor
1	R15	100KΩ, 1/4W resistor, 5%	1	Y2	3.5795 MHz crystal
1	R16	100Ω, 1/4W resistor, 5%	1	DV	LED, red
1	R17	750KΩ, 1/4W resistor, 5%	1	Q3	2N2222, NPN transistor
1	R26	330Ω, 1/4W resistor, 5%			

Install the 18 pin DIP socket at U8 -- be sure to orient the notch on the socket as shown in the parts layout in appendix C. Install the remaining components as indicated above (refer to appendix C for a

parts placement diagram). The data valid signal from the DTMF receiver is connected to the MUTE1 line -- thus, the user should leave MUTE1 disconnected when the DTMF receiver option is installed and for field installations, C5 should be removed. The Audio input to the DTMF receiver is connected to P1-1 (FF-CAD Audio input) so no further connections are required.

When the ~DLYINH signal is active, the MUTE1 feature is disabled. This allows users to "un-mute" DTMF signals and allow them to pass through the FF-CAD. As long as the delay is enabled (~DLYINH input is inactive or floating) the DTMF mute feature is active.

Receiver COS Connection

If the FF-CAD is installed in a system that does not support audio delay modules, the user must connect their COS signal to the FF-CAD to allow the module to remove the squelch burst at the end of transmissions. The MUTE1 and MUTE2 inputs are both active high which means that they must be greater than 3.8 volts to activate the respective mute function -- also, these signals must go less than 0.8 volts to properly de-activate the respective mute function. A zener diode and resistor are used at the MUTE2 input to protect the FF-CAD from voltages greater than 5V. This protection circuit can accommodate input levels up to 35V. MUTE2 requires about 1 mA of drive current to properly bias the zener diode. If the desired signal is less than 6 volts, the input protection is not required and the zener diode can be removed. With the zener diode removed, the MUTE2 input only requires about 0.1 mA for proper operation. **NOTE: any user modifications shall void the FF-CAD warranty.**

The MUTE2 input is designed to connect to an active low COS signal -- when there is no signal, the COS is high which mutes the FF-CAD output. When a signal opens the receiver squelch, the COS goes low which enables the FF-CAD output. An external inverter circuit is required to interface COS signals which are active high. An example using an NPN transistor is shown in Figure 1. Be sure to connect the 10K pull-up resistor to +12V for proper operation.

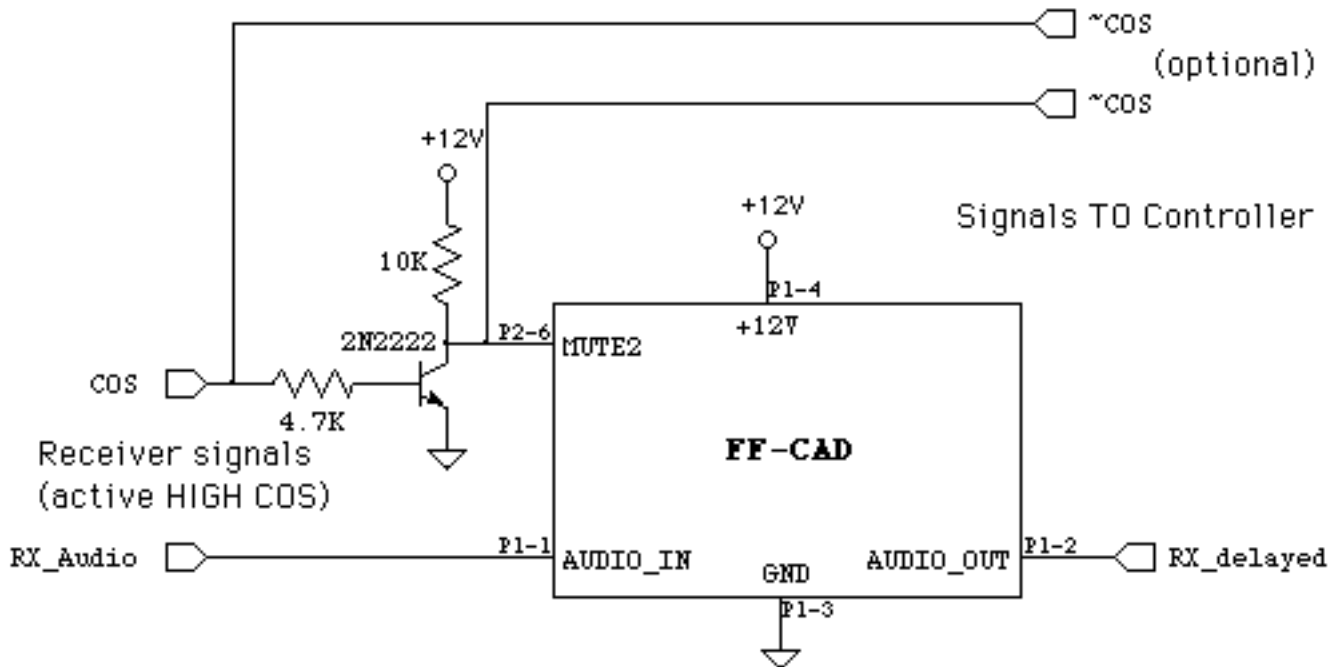
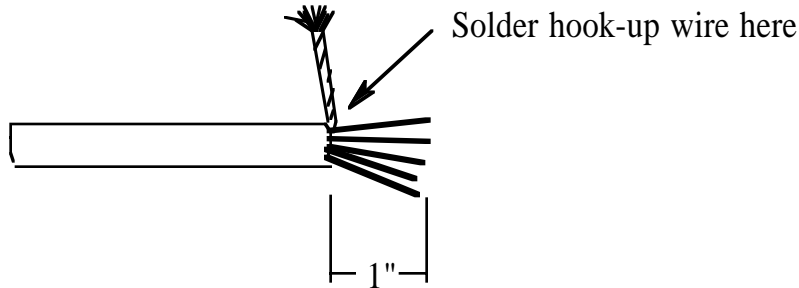

Figure 1. Connecting an active high COS

APPENDIX A FF-CAD Cable preparation

Molex housings and pins are included for the FF-CAD connectors (P1 and P2). The following describes cable preparation and Molex pin installation, refer to the "Installation" section for the connector pin-outs:



When using shielded cable, prepare as shown and solder a short piece (1 or 2 inches) of hookup wire to the shield and cut off the remainder of the shield. Cut this wire even with the others and trim 0.1" of insulation from the end of each wire. Using a pair of needle-nose pliers, crimp the exposed conductor into a molex pin as shown at (1) below. Apply a small amount of solder to establish a good connection. If too much solder is applied, it could wick down to the end of the pin at (4) -- this will make the pin difficult to insert and it may not retain properly. If this occurs, the pin should be discarded and another installed in its place. After all pins are secured, crimp at (2) around the insulation for strain relief.

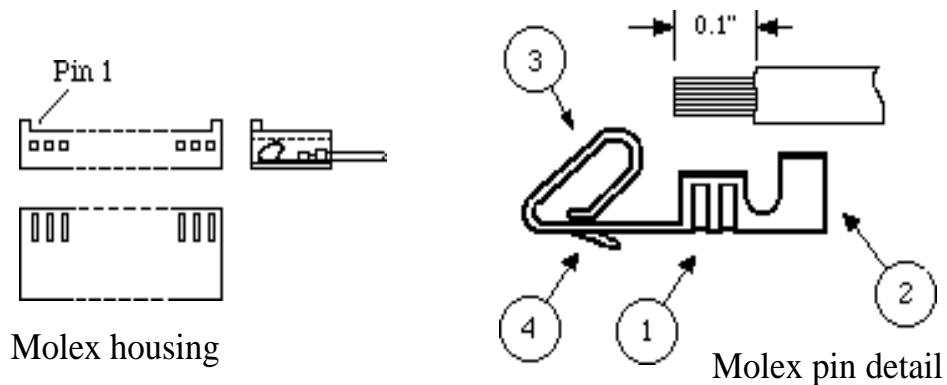

The shield wire should connect to the GND pin of the connector. When inserting the pin into the housing, be sure that the contact hook at (4) is oriented toward the slots on the side of the housing as shown above.

APPENDIX B Connection to an FF-800 repeater

For FF-800 software version 3.03 or later, use the following:

FF-800 version 3.03 introduced several output control commands which make the job of connecting remote delay signals very simple. The **Hex Out** command (user level 166) allows the sysop to enter a decimal value and have the binary/hex equivalent driven to the logic outputs. By connecting Out 1-4 to DELAY_IN[0-3], the "166" command can be used to directly enter the desired delay setting.

For FF-800 version 3.02 or earlier, use the following:

This section describes some connection and programming schemes that allow the user to remotely set the delay time from any FF-800 repeater controller. The following discussion uses outputs 1 through 4 on the FF-800 -- the user may use any four outputs (including the external shift register outputs) by modifying the appropriate programming steps. Figure B1 shows a simple circuit using a 74HC193 pre-settable counter I.C. that is connected to the FF-CAD delay inputs. For this circuit J1 on the FF-CAD need not be modified, simply set the rotary delay switch to position "0". The power-up delay pre-set inputs are used to define the "default" delay that the FF-CAD will use on power-up. Table 1 illustrates the 4-bit codes that correspond to each delay setting. For each bit that is "0", ground the appropriate pre-set connection. Bits that are "1" are connected to the pull-up resistors. A 4 position DIP switch may be used to allow this default setting to be easily changed.

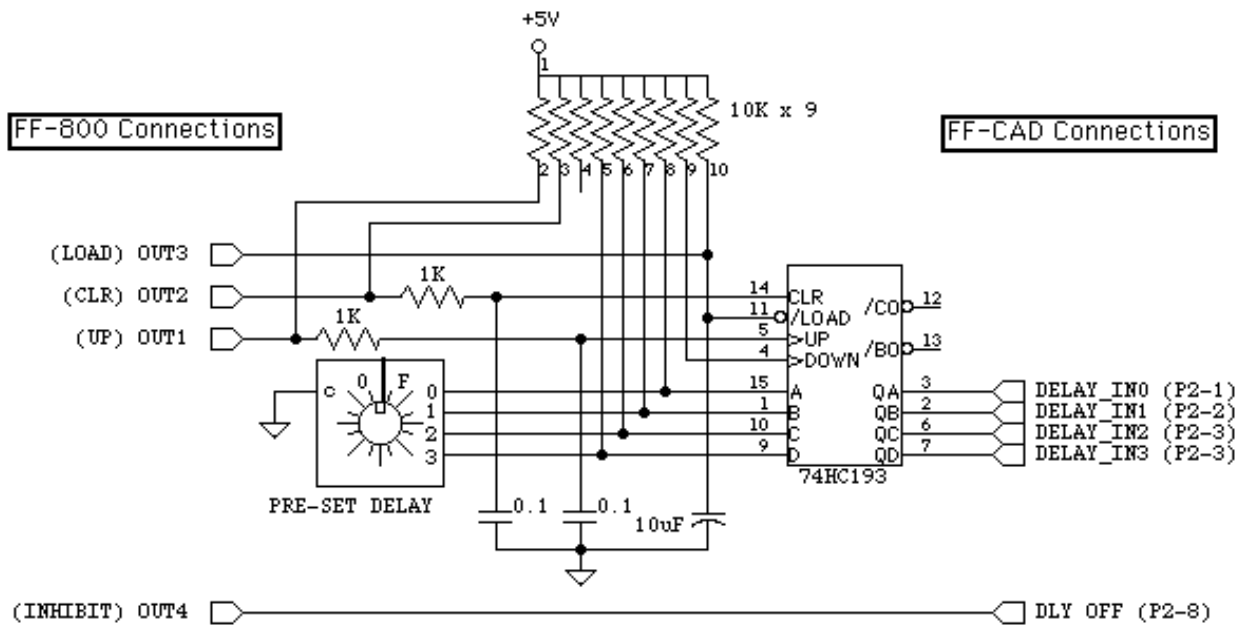

Figure B1. Remote delay circuit for the FF-800.

PROGRAMMING THE FF-800

The following describes the function of each of the four FF-800 outputs:

FF-800	Normal setting	Description
OUT1	ON	Clocks the "up" input to the counter
OUT2	OFF	Resets the counter to "0000"
OUT3	ON	Loads the "preset" delay (optional)
OUT4	ON	turns off the delay function (optional)

The "Normal setting" column indicates the normal state of the output (assuming all four outputs are set to active high). Each of the outputs must be manually set to the state indicated -- state 1 of the repeater must be saved after the normal settings have been entered so that these outputs are properly initialized when the FF-800 is powered-up.

The following sequence illustrates the sequence to initialize the outputs (default prefixes used):

11511	Set outputs
"Set Out One On"	
11520	
"Set Out Two Off"	
11531	
"Set Out Three On"	
11541	
"Set Out Four On"	
100	Unlock security
"O K"	
139	
"O K"	
014801	Save state 1
"Set Machine Set One"	

If there are any other states in use, these must be recalled (00480n ; n = state number), the normal settings manually entered, and then saved (01480n ; n = same state number).

Once the outputs have been initialized, the control macro must be entered. The following assumes default prefix codes:

Step 1: Choose an empty or un-used macro number
Step 2: Enter the following macro. Be sure to adjust the following if you have used outputs other than those described.

100	unlock security
"O K"	
139	
"O K"	
01590	set macro enter mode
"M R O Enter"	
001	suppress speech
"ME"	
11511	initialize "clock" output
"ME"	
11521	pulse "clear" output
"ME"	
11520	
"ME"	
001	enable speech
"ME"	
01599	parameter designate
"ME"	
1271	pulse output #1
"ME"	
0159211	save to macro #11 (use your macro # here)
"Complete"	

APPENDIX B Connection to an FF-800 repeater (continued)

To use this macro, enter the macro prefix (here it is "1221") followed by the two digit delay number from "00" to "15" (refer to the "#" column of figure 1). Thus, to set a delay of 6 (0110 bit pattern) enter "122106" -- this results in a delay of 109.4 ms for a 2K delay memory (see table 1).

Optional Outputs

If desired, output #3 can be used as illustrated in figure B1 to "re-load" the pre-set delay time. for this, simply pulse output 3 once using "1273".

If the delay is to be inhibited (ie., for repeater tests), output #4 can be turned on or off using "1154" + "1" or "0". With active high outputs, "ON" responses mean delay on, and "OFF" responses mean delay off.

If either of these features is NOT desired, simply leave those connections (ie., OUT3 and/or OUT4) disconnected.

APPENDIX C PTT Hang Time Option

The PTT Hang time option is a factory installed modification that allows the FF-CAD to drive a transmitter PTT (PTT_{out}, P2-5) such that the transmitter is keyed as soon as PTT_{in} (P2-6, a.k.a. MUTE2) goes active, but remains keyed after PTT_{in} goes inactive. The amount of time that the PTT_{out} remains keyed is equal to the current audio delay plus two delay steps. Thus, if the delay step is 15ms, and the FF-CAD delay switch is set to 0 (which equals 1 delay step), the PTT delay is $T(\text{hang}) = (\text{dlysw} + 1 + 2) * 15\text{ms} = 45\text{ms}$.

Refer to figure C1 for a diagram describing the hang time operation. While in the hang time mode, MUTE2 (P2-6) is the PTT input and P2-5 is the PTT output. The PTT input expects a signal that is less than 0.8V to key the TX, which is what the FF-CAD provides at P2-5. To unkey, the signal at P2-6 must either float, or go to at least 4.5V (the PTT_{in} signal may go as high as 40 volts without risk of damage to the FF-CAD). When the PTT Hang time mode is installed, the audio mute function of MUTE2 is controlled by the MUTE2 Mode jumper (see Figure C2, below). When "ON", the audio is muted when PTT_{in} is high, and audio is passed when PTT_{in} is low. When "OFF" is selected, the audio is never muted. Note that the MUTE2 jumper is only recognized when power is applied to the FF-CAD. If the jumper is changed while power is applied, the FF-CAD must be power cycled for the mode change to be recognized.

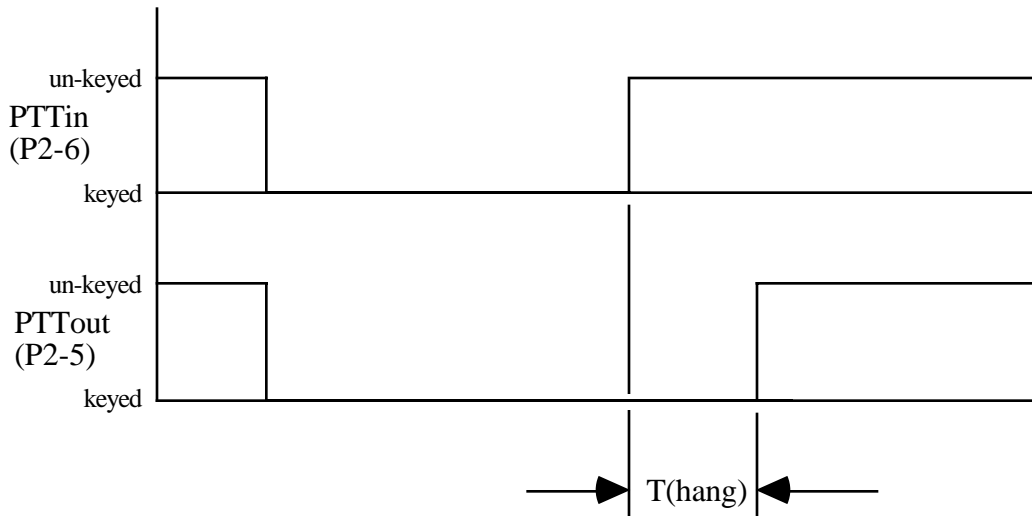

Figure C1. PTT input/output timing

Note that the PTT hang time feature is disabled when the delay inhibit is active. While the delay is inhibited (audio passes with no delay) the PTT output will follow the PTT input with no hang time applied.

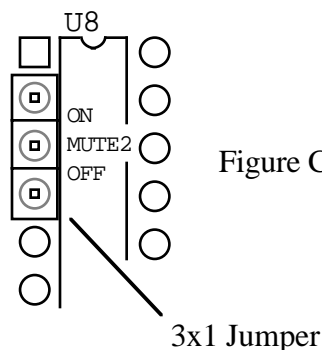

Figure C2. MUTE2 Mode Jumper Detail

APPENDIX D Parts list and schematic

FF-CAD Parts List

<u>Designation</u>	<u>Description</u>
C1,2	22 pF, ceramic capacitor
C3,8	10 μ F 25V, electrolytic capacitor
C4,5,6	0.01 μ F, ceramic capacitor
C7,13,14, 22	0.1 μ F, ceramic capacitor
C10	470 pF, ceramic capacitor
C11,12	1 μ F non-polarized electrolytic capacitor
C15,16,17	100 μ F 25V, electrolytic capacitor
Y1	8.192 Mhz crystal
R1	10M Ω , 1/4W resistor
R2,20,21	2.4K Ω 1/4W resistor
R3-6,19,22,23	20K Ω , 1/4W resistor
R8	100 Ω , 1/4W resistor
R9,10,11	1K Ω , 1/4W resistor
R12	100K Ω , 1/4W resistor
R13	120K Ω , 1/4W resistor
R18	330 Ω , 1/4W resistor
R24,25	4.7K Ω , 1/4W resistor
R27,28	20K Ω , 1/8W SMD resistor, 1206 pkg.
RP1	20K Ω x 9 resistor pack, pin 1 common
D1	15 V transorb circuit protector
D2	1N4733, 5.1V zener diode (solder side, under C4)
Q1,2	2N2222 NPN transistor
U1	MC68HC711D3-CFN2 microcontroller I.C.
U2	MC6264 memory I.C.
U3	TCM29C16 μ Law codec transceiver I.C.
U4	LM7805 5V regulator I.C.
U5	ICL7660 DC-DC converter I.C.
U6	MC34164P-5 voltage level detector I.C.
U7	4040 ripple counter I.C.
U9, 10	74HC573 octal latch I.C.
SW1	16 position, HEX code rotary switch
P1	4 pin Molex header
P2	9 pin Molex header

DTMF Detect Option:

C18, 21	0.1 μ F, ceramic capacitor
C19	470 pF, ceramic capacitor
C20	10 μ F 25V, electrolytic capacitor
Y2	3.5795 Mhz crystal
R7	2.4K Ω 1/4W resistor
R14, 15	100K Ω , 1/4W resistor
R16	100 Ω 1/4W resistor
R17	750K Ω , 1/4W resistor
R26	330 Ω 1/4W resistor
U8	M8870-1 DTMF receiver I.C.
Q3	2N2222 NPN transistor
DV	LED, red

If the DTMF option is installed, omit the following components:

R10, R23, C5

APPENDIX D Parts list and schematic (continued)
FF-CAD Parts Layout

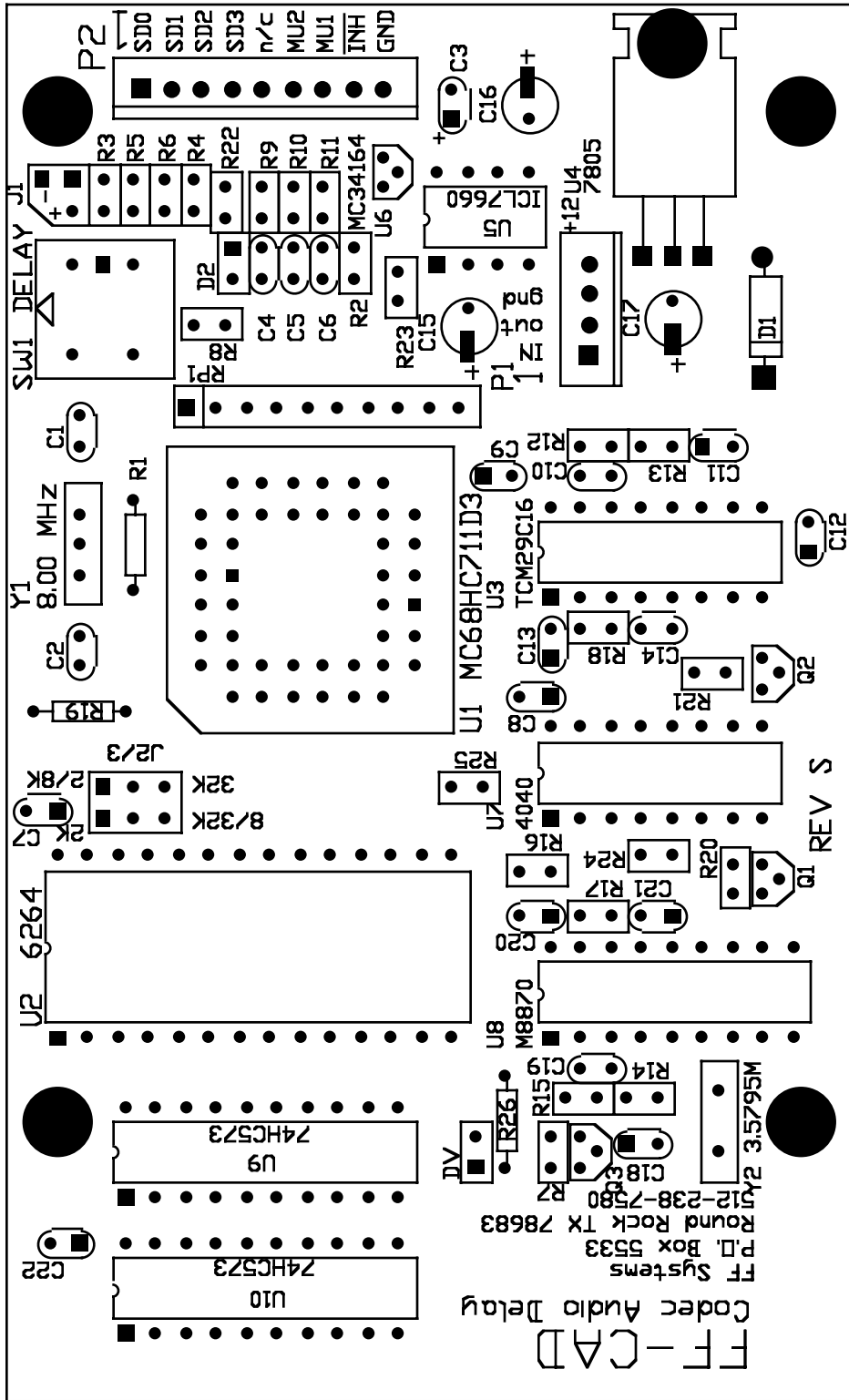

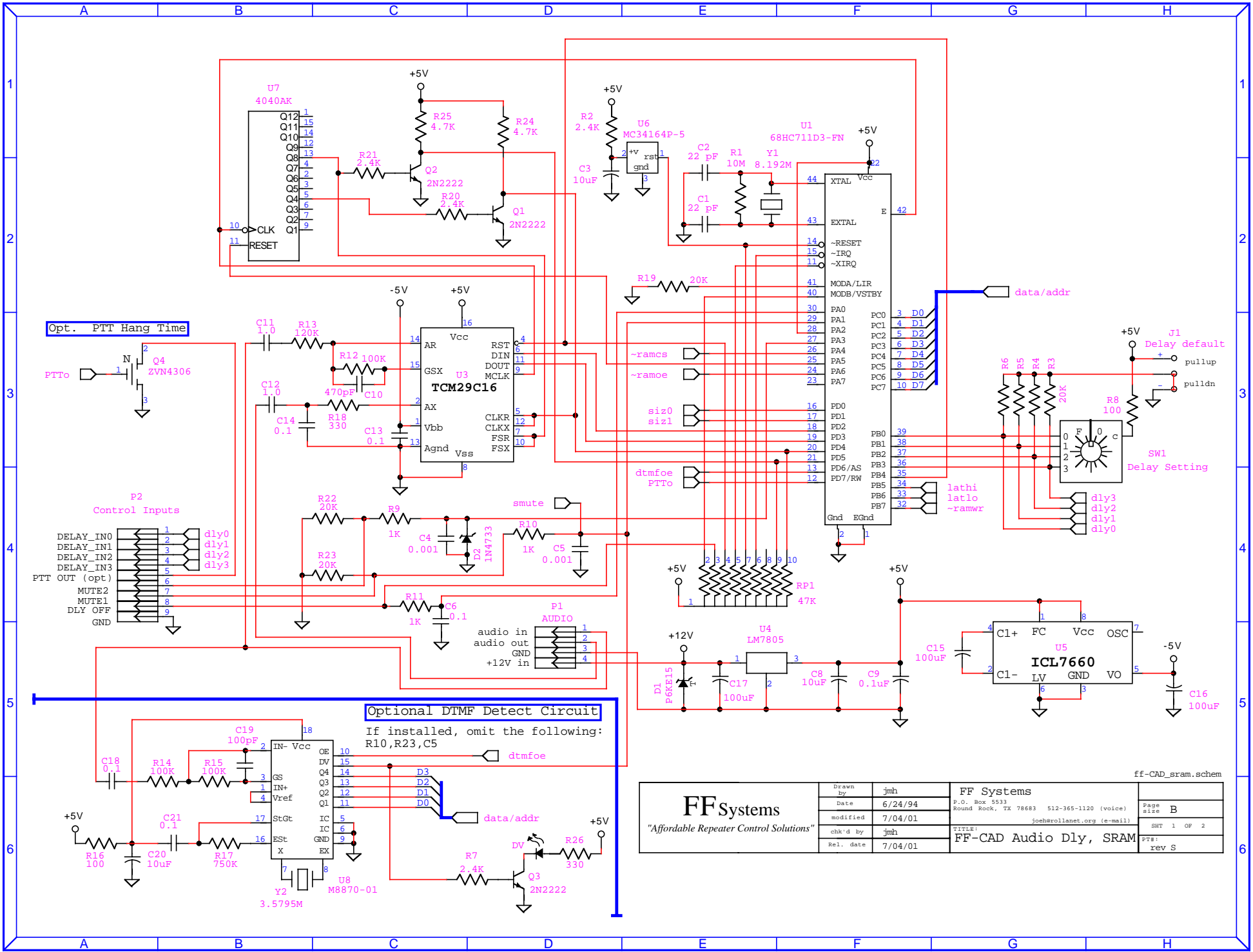

Opt. PTT Hang Time

Optional DTMF Detect Circuit

If installed, omit the following:
R10, R23, C5

FF Systems "Affordable Repeater Control Solutions"		Drawn by: jmh Date: 6/24/94		FF Systems P.O. Box 5533 Round Rock, TX 78683 512-365-1120 (voice)		Page size: B	
		modified: 7/04/01 chkd by: jmh Rel. date: 7/04/01		joebarollanet.org (e-mail)		SHT 1 OF 2 PPS: rev S	

ff-CAD_sram.schem

Normal Config.

Opt. PTT Hang Time

Opt. PTT Hang Time with MUTE enabled

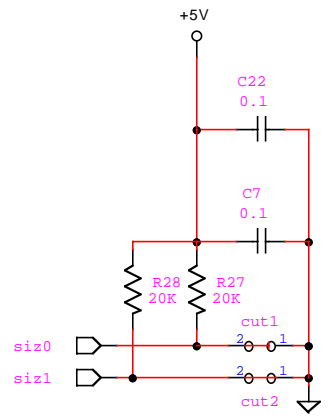
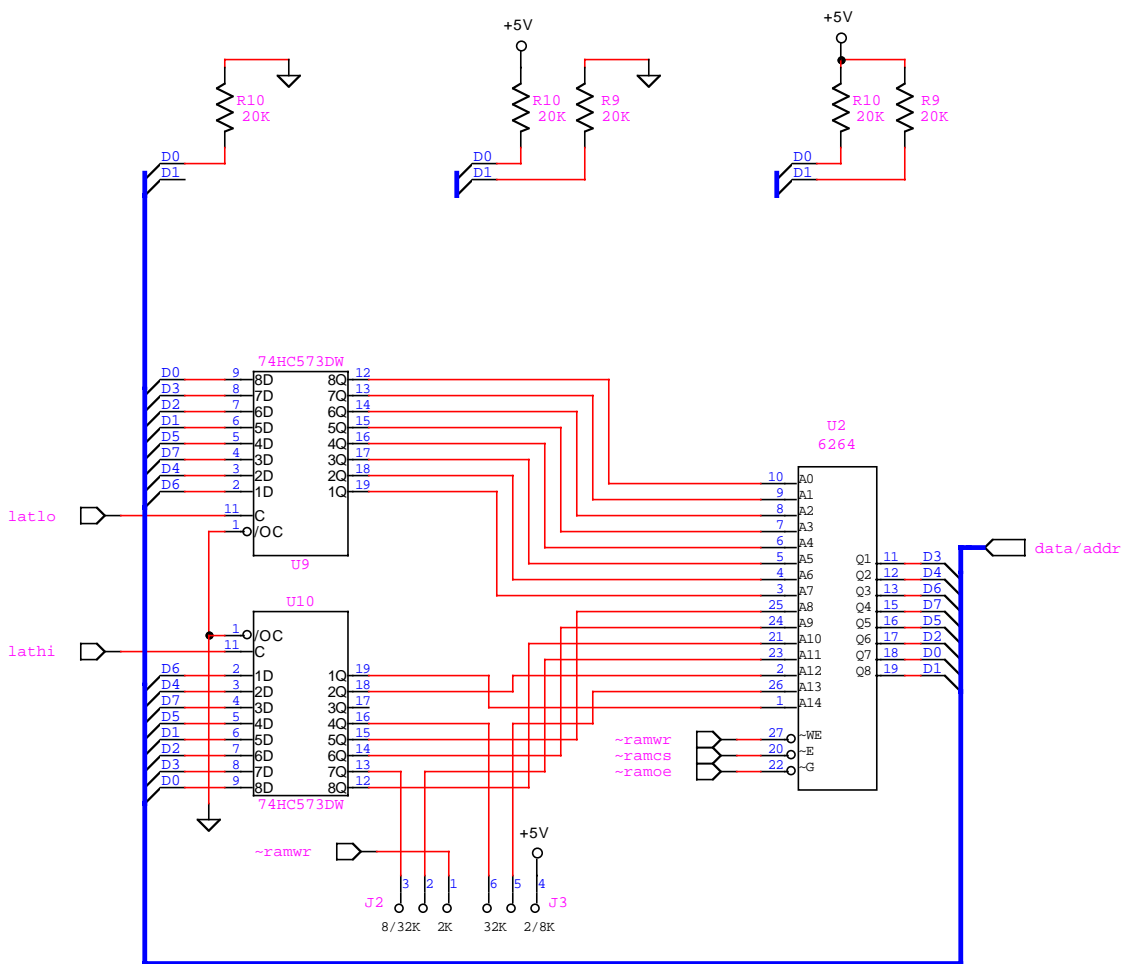

- NOTES:
- 1) J2 & J3 select physical device size, 2K, 8K, or 32K.
 - 2) siz[1:0] selects delay step size:

*siz1	*siz0	delay step	max dly	min SRAM size
0	0	15 ms	250 ms	2K
0	1	32 ms	500 ms	8K
1	0	64 ms	1000 ms	8K
1	1	256 ms	4000 ms	32K
 - 3) siz[1:0] setting only recognized on initial power.
- *- 0 = pad shorted to GND
1 = pad cut (open)

ff-CAD_sram.schem

FF Systems <i>"Affordable Repeater Control Solutions"</i>	Drawn by	jmh	FF Systems P.O. Box 5533 Round Rock, TX 78683 512-365-1120 (voice)	Page	
	Date	6/24/94		Round Rock, TX 78683 512-365-1120 (voice)	size
	modified	2/25/03	joeh@rollanet.org (e-mail)	SHT	2 OP 2
	chk'd by	jmh	TITLE:	FF-CAD Audio Dly, SRAM	PTC:
Rel. date	2/25/03			rev	S

APPENDIX D Parts list and schematic (continued)

FF-CAD Dimensions

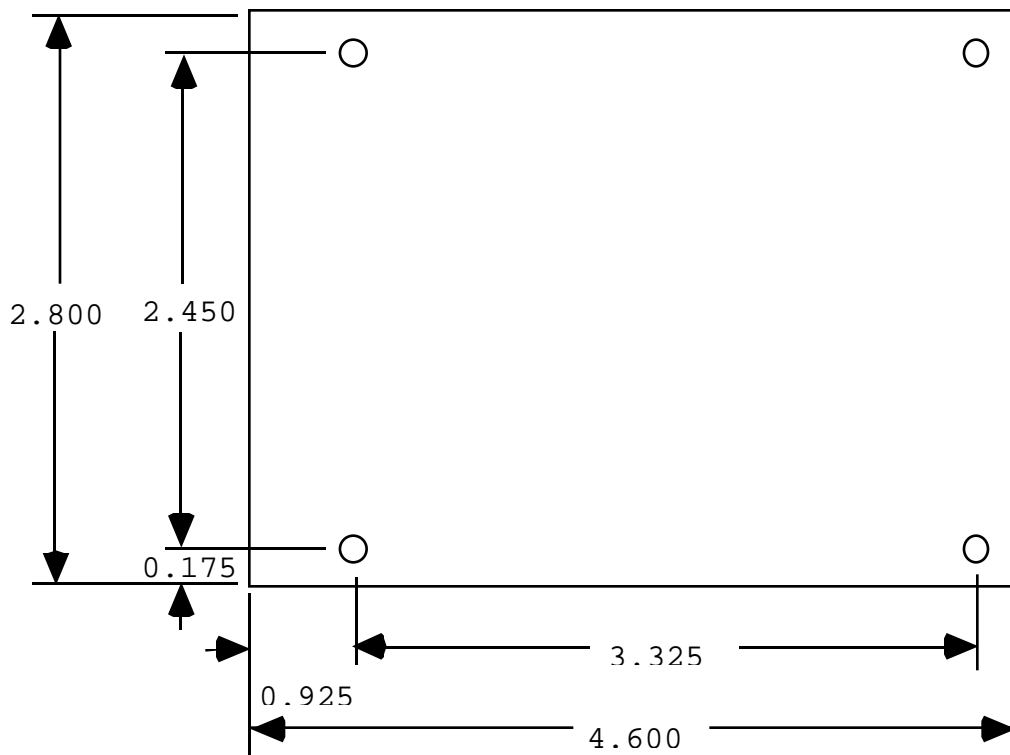

Figure C1. FF-CAD board dimensions
(not to scale)