

# FF-8070

## Operations Manual

### Digital Voice Recorder



P.O. Box 5533  
Round Rock, TX 78683  
512-365-1120 (voice)

*" AFFORDABLE REPEATER CONTROL SOLUTIONS "*

## **FF-8070 Digital Voice Recorder V2.24**

### Table of Contents

Warranty.....	1
Introduction.....	2
Operation Overview.....	2
Installation.....	3
DVR Functions.....	3
User Commands.....	4
Configuration Commands.....	7
FF-800 Interface Programming.....	10
FF-8070 Command Examples.....	11
Adjustments.....	13
APPENDIX A	
FF-8070 WIRING.....	14
APPENDIX B	
FF-8070 Track Allocation.....	15
APPENDIX C	
Adding DRAM.....	15
APPENDIX D	
Schematic and Parts List.....	16

## Warranty

FF Systems warrants its products to be free from defects for one year from the date of shipment. FF Systems may opt to repair or replace (at our option) any defective product. FF Systems does not warrant any defect due to lightning or other natural disaster. Any user modifications or repairs to any product sold by FF Systems shall void this warranty. All returns must be accompanied by a Return Material Authorization (RMA) number provided by FF Systems prior to shipment. Shipments that do not have the proper return authorization prominently noted on the outside of the package will not be accepted. The purchaser is responsible for all shipping charges for any service procedure(s) performed by FF Systems (including warranty service).

## 30 Day Money Back Guarantee

FF Systems offers a 30 day trial period on all products. The 30 day trial begins 5 calendar days after shipment from FF Systems. If the purchaser decides to return a product they must contact FF Systems for a Return Material Authorization (RMA) number on or before 6:00pm central time within 35 calendar days of the original shipment date. The purchaser then has fourteen additional calendar days to return the merchandise to FF Systems. FF Systems claims no liability for lost or mis-directed shipments. The purchaser is responsible for all shipping charges.

## Product Condition

Products must be in new condition or warranty repairable to qualify for refund. If merchandise incurs damage not covered under warranty, the refund will be delayed until the unit has been repaired and the cost of that repair shall be deducted from the refund. FF Systems is not responsible for damages incurred during shipment -- the purchaser should insure the merchandise for the purchase amount to avoid possible loss due to damage during shipment.

## Contact Address

FF Systems  
P.O. Box 5533  
Round Rock, TX 78683  
512-365-1120 (voice)

e-mail: [joeh@rollanet.org](mailto:joeh@rollanet.org)

web: <http://www.rollanet.org/~joeh/>

## Introduction

The FF-8070 DVR (Digital Voice Recorder) is a microprocessor controlled audio record and playback interface designed for the FF-800 Repeater Controller. The FF-8070 accepts DTMF commands and audio via the FF-800 and includes provisions for record or playback from the FF-800 control autopatch. The recording of messages is divided into three areas: 1) System tracks, 2) Voice mail, and 3) Audio test. System messages are primarily used by the FF-800 (as assigned by the user) to play DVR tracks in ID bulletins, function annunciators, tail messages, etc.... The voice mail and audio test features are primarily for use by repeater users via DTMF commands.

The voice mail feature allows users to record and receive messages. The status of the mail box can be interrogated manually (allowing users to interrogate the mailbox to see if they have any messages), or the FF-800 may automatically poll the mailbox status via speech macro commands. The audio test records a sample of audio up to 20 seconds long on a test track and immediately replays the test track to provide users with a means of monitoring their signal quality -- this feature is also useful for adjusting the DVR levels after installation.

It should be noted that the system tracks and the mail box tracks are separate and there are different command sets to record and play the two types of tracks. NOTE: the audio test and mail box tracks can not be directly accessed by the FF-800 speech macro commands. Speech macros are special "words" that are used in FF-800 messages to trigger the DVR play a track.

## Operation Overview

The FF-8070 DVR uses Continuously Variable, Slope-Delta (CVSD) modulation to store audio signals as a stream of single bit values. The system must over-sample to eliminate the carrier frequency -- in this case the sample frequency is 50KHz. The bit stream is stored on 1 megabit DRAMS each of which can hold about 20 seconds of sampled audio. The FF-8070 comes standard with 8 one megabit DRAMS with room for additional memory (up to a maximum total of 32 DRAMS).

The DVR memory architecture is organized as 8 banks of 4 DRAMS each, which means that you should add memory to the DVR in blocks of 4 devices at a time. The memory expansion connector (P1) allows the FF-8070EXP memory expansion board to be installed which allows an additional 32 DRAMS for a total of 64 megabits of storage (over 21 minutes of total audio record time). The DVR separates the banks of memory into "system" and "mailbox" areas. By selecting how many mailbox tracks you desire (**# MAIL Tracks**, command suffix <053>), the system will allocate the number of banks available to the system tracks. Note that the mailbox tracks are selected at the expense of system track memory. The factory defaults is to select 3 mailbox tracks. This takes one bank of DRAM, which leaves one bank available for system tracks (given the 8 DRAMS that are factory standard).

There are 100 system tracks available (7 of which are used as prompts for the voice mail) and these tracks reside in the system section of the DVR memory. The FF-8070 DVR is a random access system, which means that tracks can be recorded and rerecorded as often as desired without any special consideration for any previous record operations. The only stipulation is that the maximum record time of each track can not be exceeded. Each track is allocated a certain maximum record time, this time can range from one second up to 83 seconds for an individual track. Each track is preallocated at the factory but the user can modify the record time allocations for the system tracks to meet their special needs. Tracks can be reallocated after the DVR has been in service, but all reallocated tracks must be rerecorded -- appendix B discusses the allocation process in more detail.

The mail box section holds the mail box tracks as well as the DVR test track. Thus, if the user

turns off the mail box (by selecting 0 mailbox slots), the DVR test feature is also disabled. If the mail box is turned off, the seven prompt tracks can be used as general system tracks. On power up, the DVR clears all tracks (but not configuration data like prefixes, record time allocations, etc..., these are maintained in nonvolatile memory). Thus, the mail box prompt tracks must be recorded after power up in order for the mail box prompts to function properly. A battery back-up connector is provided to maintain the DVR speech memory in the event of a power failure. The installation section discusses the connection of an appropriate battery.

## Installation

The wiring of the DVR is accomplished through three connectors on the FF-8070 board. The following lists those connectors along with their signal descriptions: ~ = Active low signal

P2: Battery ( <i>molex 3 pin</i> )	* P3a: DVR I/O ( <i>IDC 10 pin</i> )	* P3 (legacy) ( <i>molex 9 pin</i> )	P5: SPI Bus ( <i>IDC 10 pin</i> )	* P3: DVR I/O ( <i>2 pin header</i> )
1) Battery (-)	1) DVR in (A)	1) DVR in (A)	1) MOSI	2) GND
2) Battery (+)	2) GND	2) GND	2) GND	3) ~CMD unlock
3) Battery (-)	3) DVR out	3) ~CMD unlock	3) SPCK	
	4) GND	4) n/c	4) GND	
	5) GND	5) n/c	5) MISO	
	6) GND	6) DVR in (B)	6) GND	
	7) DVR in (B)	7) DVR out	7) ~RST1	
	8) +12V in	8) +12V in	8) n/c	
	9) GND	9) GND	9) n/c	
	10) +12V in		10) Reset	

\* Note: legacy P3 connector supports FF-800 controllers manufactured prior to 2001 and is generally not installed.

P1 & P4 are for DVR expansion and their pin-outs are detailed in the schematic for user reference. The battery input (P2) should be connected to a battery for maintaining DVR operation during power interruptions. The battery must be greater than 9 volts across its discharge cycle, and less than the voltage at P3-8 for proper operation. A 3 AHr lead-acid-cell will maintain power for over 30 hours. It is generally recommended that a 12V battery be used with at least 1Ahr of capacity. Note that the FF-8070 has no provisions for charging the back-up battery, an external charge/maintenance system must be supplied by the user.

P3a and P5 use factory supplied ribbon cables to connect to the FF-800. P3a on the DVR connects to P25 on the FF-800, while P5 on the DVR connects to P7 on the FF-800.

The FF-8070 card should be placed in an RF tight enclosure and be placed as close as practical to the FF-800. It is recommended that the FF-8070 be installed in the same chassis as the FF-800 to allow the cable lengths to be kept to a minimum.

## DVR Functions

The FF-800 SPI interface commands use a prefix-suffix syntax. The user-defined prefixes may be 1 to 4 digits long and are used to access the various interfaces connected to the FF-800 SPI bus. The SPI protocol assigns a fixed address to each interface that is connected to the bus. These addresses are factory defined and are used to differentiate the devices (the FF-800 does not have any specific programming that differentiates one address from another). The DVR address is 6, so the FF-800 commands for accessing the DVR are the **SPI #6 Command** (default 130) or the generic **SPI Command** plus the address "6" (default 1266). One of these prefixes must precede

the DVR commands described herein. Note that these prefixes are defined using the FF-800, not FF-8070 commands. If they have been modified for your system, you must use the new prefix when entering DVR commands into your system (all examples illustrate the default prefix codes).

The suffix codes form the "tail end" of the DVR command syntax. These are the DTMF digits that specify which DVR command is to be executed and may include one or more digits of user specified data. In addition, four of these suffix codes can be user defined as shown below.

<u>User Defined suffixes:</u>	<u>Factory Default</u>
Record mail slot	*
Erase last played mail slot	**
Audio Test	***
List active Mail Slots	blank (no digits)

The following list describes the FF-8070 command suffixes. These commands are used to set system parameters or record system tracks. NOTE: all DVR command digits must be preceded by a FF-800 SPI prefix digits:

<u>suffix code</u>	<u>DESCRIPTION</u>
00	Play system track
01	Record system track.
01*	Interrogate system track size.
02	Set input source. Selects main or aux. (phone patch) DVR input.
03*	System track erase.
040	Search system track -- short play.
041	Search system track -- long play.
050	lopoff (start) configure.
051	End lopoff (end) configure.
052	Set number of installed DRAMs.
053	Set number of mailbox tracks.
054	Set "Audio Test" suffix.
055	Set "List active slots" suffix
056	Set "Record mail" suffix
057	Set "Erase last played" suffix
0580	Set Voice Mail Auto-play delay time.
0581800	Clear user defined suffixes
0582	Set Voice Mail Auto-erase time.
059	Blank annunciate mode.
05*	Set Security code.
060800	Execute BASIC initialization.
061	ADVANCED initialization code.
066	Force mail box message erase
067800	Save configuration flag modes.
069	Set track interrupt mode.
07	Record system track with no play-back
08	Version request. Responds with the interface model and serial number.
09	Security lock/unlock

## User Commands

<b>Input Source Set</b>	Sets source of record audio to the DVR (main or aux)
	<spi prefix> + <02> ; <1 or 2>                      1 = main, 2 = aux
default	13002    interrogate



<u>SYS TRACK #</u>	<u>Track function:</u>	<u>Examples:</u>
• Track 00	message address prompt	"Who is your message for"
• Track 01	record prompt	"Record your message"
• Track 02	messages waiting	"There are voice messages"
• Track 03	no messages	"Sorry, there are no messages"
• Track 04	message clear	"Your message has been erased"
• Track 05	message saved	"Your message has been saved"
• Track 06	mailbox full	"Sorry, the mailbox is full"

These tracks should be recorded after each cold-start (a cold start is when the DVR is powered on after a full power loss). Note that any DVR recording will be lost if the DVR loses power at both the normal and battery power connections. The mailbox function will still operate even if these tracks are not recorded, but the prompting will not be informative to those who are not familiar with the mail slot recording process.

After entering the record voice mail command, the DVR responds with track#00 ("who..."). The user simply keys their transceiver, speaks an appropriate address, and then releases their push to talk. The DVR then responds with track#01 ("record...") at which time the user keys again and records their message. After the message is recorded (PTT released) the DVR responds with track#05 ("message saved..."). The record cycle is now complete and the message can be retrieved at any time by the addressee.

If all the available voice mail message slots are in use, the DVR will respond with track#06 ("full...") instead of track#00. If this occurs, no more messages can be stored until one or more of the active messages is erased. Also, there is a time-out limit of 5 seconds after each prompt -- if no COS is engaged within this time, the mailbox operation is aborted.

To query the mail box, the "list active messages" command is entered. If there are no active messages, the DVR responds with track#03 ("no messages..."). If one or more active messages are present, the DVR reads back the slot number followed by the address header for each active message. The slot number of the message headers is important in that this corresponds to the number entered to retrieve the message track. NOTE: The DVR does not count inactive messages during the list operation. This means that if a message is deleted, any active message numbers that follow it will be decremented by one on subsequent list queries. Thus, a message track may start at slot number 3, but end up at slot number 1 if the previous two messages are deleted (and no other slots are recorded).

When the play message slot function is entered, the DVR looks for the n-th active message. If active, the header and message are played-back. After the playback is complete, a 60 second timer is activated during which the message erase function can be entered to clear the message track. If the erase is successful, the DVR responds with track#04 ("message clear..."). If there is no response to the erase command, then the erase was not successful.

**Version** Interrogate the FF-8070 software version.  
 <spi prefix> + <08>  
 default 13008

Responds with the interface software revision and serial numbers. This command is useful to verify that the interface communications are functioning properly. The FF-800 **Version Interrogate** command (01800) will also interrogate the FF-8070 version and serial numbers.



<b>Security</b>	Security access command	
	<spi prefix> + <09> ; <nnn>	Unlock security access
default	13009	lock access
	13009nnn	unlock

This command must be entered prior to accessing the configuration commands if a security code has been programmed. Entering the prefix with out the code, or with an invalid code, will lock the system (which should be done after a configuration session is complete). The security access automatically expires 15 minutes after the last entry of a configuration command. It should be noted that this command is totally unrelated to the FF-800 security commands. NOTE: If the security prefix is set to blank (no prefix), then security is ALWAYS unlocked, and this command has no affect on the status of security. The factory default is a blank security code.

## Configuration Commands

NOTE: All configuration commands require that the DVR security be unlocked or disabled.

<b>Set security code</b>	<spi prefix> + <05*d..d>
default	13005*d..d
response:	"P F X" if new prefix is OK "Abort" if new prefix is a duplicate of an existing prefix or if CMD unlock jumper removed.

The security code "d..d" can be between 0 (blank) and 3 digits long. Zero digits for "d..d" disables the security feature (this is the factory default). Note that the CMD unlock jumper (P3) must be installed to set the security code.

<b>Record system track</b>	<spi prefix> + <01nn>	Record track #<nn>
	<spi prefix> + <01*nn>	Interrogate track length
	<spi prefix> + <07nn>	Record (no play-back)
default	13001nn	record
	13001*nn	interrogate track length
	13007nn	record w/ no play-back

The record time of the new track can not exceed the allocated time or an error message will result and the original track will be lost -- refer to appendix B for a listing of the BASIC initialization allocations. The <01\*nn> format allows the user to interrogate the amount of time allocated to the indicated track. The response is in seconds and provides the user with a means to interrogate the maximum length allocation for any track. The record protocol is as follows:

- Enter 13001nn (nn = track# to record) and wait for the "DVR" response from the FF-8070(or "DVR B" if source = auxiliary) -- the DVR waits for a COS signal (or any DTMF digit if input=B) at which point the recording operation begins.
- Recording continues until the loss of COR (or any DTMF digit if input=B) or until the end of track is reached. There is no alert for end of track over-run.
- After the record operation, the track is played back and the record cycle is complete (this step is skipped for the no play-back command).

There is a time-out limit of 5 seconds after the "DVR" response -- if COS (or DTMF digit if input=B) is not engaged within this time, the record operation is aborted with no change to the original track.

**System track erase**     <spi prefix> + <03\*nn>  
 default                    13003\*nn

Erases the system track# <nn> from the system. It is not necessary to erase a system message before rerecording.

**Force Mail Erase**             <spi prefix> + <066nn>                    Erase Mail box Track(s)  
 default                    130066nn

Forces an erase of mail box message track number <nn> without having to interrogate the contents of the mailbox slot. If there are not <nn> active messages, this command is ignored. If <nn> = "0", all of the active messages are erased (leaving the mail box completely empty).

**Play system track**             Play system track.  
                                      <spi prefix> + <00nn>                    Play track number "nn"  
                                      <spi prefix> + <041> ; <nn>                Search tracks starting at track# "nn"  
                                      <spi prefix> + <040> ; <nn>                Search tracks -- short play version  
 default                    13000nn                                    Play track  
                                      130040nn                                  Search tracks, short  
                                      130041nn                                  Search tracks

The search tracks formats are used to sequentially play a range of system tracks. The DVR starts at track# <nn> (or track# 00 if <nn> is omitted) and sends the track number followed by a playback of the track for each of the remaining tracks. This format is useful for locating a track if the number has been forgotten. The search continues until a COS is detected or until the last recorded track is encountered (blank tracks are skipped). The search long function plays each track in its entirety, while the search short only plays the first 1 second of each track.

**LOPSTART A**                    <spi prefix> + <050> ; <nnn>             Start lop-off: input A (milliseconds)  
**LOPEND A**                     <spi prefix> + <051> ; <nnn>             Stop lop-off: input A (milliseconds)  
**LOPSTART B**                    <spi prefix> + <050\*> ; <nnn>            Start lop-off: input B (milliseconds)  
**LOPEND B**                     <spi prefix> + <051\*> ; <nnn>            Stop lop-off: input B (milliseconds)  
 default                    130050nnn                                Start, input A  
                                      130051nnn                                Stop, input A  
                                      130050\*nnn                               Start, input B  
                                      130051\*nnn                               Stop, input B

The "lop-off" values are the amount of time that subtracted from the beginning or end of each recorded track. This allows the elimination of switching and squelch noise from the beginning and/or end of tracks which gives a "clean finish" to the DVR tracks. If the system has a long squelch burst, or some other artifact that is heard at the beginning and/or end of a recorded track, then these values may be increased to remove the particular artifact. NOTE: it is not necessary to rerecord tracks for new lop-off values to take affect, this value is used in play-back only, so the values may be changed any number of times without altering the original track recordings.

**LOPSTART A** and **LOPEND A** affect all tracks recorded from the "A" input while **LOPSTART B** and **LOPEND B** affect all tracks recorded from the "B" input. The Audio Test track does not use the lop-off functions, so squelch noises or DTMF "blips" observed on this track are normal.

<b># DRAMS Installed</b>	<spi prefix> + <052> ; <nn>	Set number of DRAMs installed
default	130052	interrogate current setting
	130052nn	set to "nn"

In order to properly store and retrieve tracks, the DVR firmware must know some information about the hardware configuration of the interface. The number of installed DRAMS is preset at the factory for the amount of memory that the DVR shipped with -- however, if additional memory is later added, this value must be changed to reflect the number of DRAMs installed. Refer to appendix C for details on adding DRAM.

<b># MAIL Tracks</b>	<spi prefix> + <053> ; <nn>	Set number of mailbox tracks
default	130053nn	interrogate current setting
	130053	set to "nn"

This function should not be executed until after the **# DRAMS Installed** function is updated (only required if there is a change in the DRAM configuration). The user may allocate mailbox tracks within the following limits: 0, 3, 7, 11, 15, 19, 23, 27, or 31. If any other number for <nn> is entered, an error will result. The selection of 0 mailbox tracks turns off the mailbox and audio test functions. The mailbox allocation is restricted by the number of DRAMS installed. The maximum number of mailbox tracks = #DRAMs - 5. Selecting a number greater than that given by this equation will also result in an error. It should also be noted that adding mailbox tracks takes away system tracks. Thus the user must balance the available memory with the requirements for system tracks and mailbox tracks. If this balance is difficult to achieve, then it may be necessary to add more memory.

**Set User Defined Prefixes:**

<b>Set "Audio Test" suffix</b>	<spi prefix> + <054d..d>
<b>Set "List active" suffix</b>	<spi prefix> + <055d..d>
<b>Set "Record mail" suffix</b>	<spi prefix> + <056d..d>
<b>Set "Erase mail" suffix</b>	<spi prefix> + <057d..d>

response: "P F X" if new prefix is OK  
 "Abort" if new prefix is a duplicate of an existing prefix.

The four mailbox codes can be between 0 (blank) and 3 digits long. These codes should not begin with a numeric digit (although "0" is generally OK), and users can not duplicate any codes used for configuration. The firmware compares the new <d..d> code with all of the existing system and mailbox codes before validating the entry. Thus, none of the mailbox codes can duplicate any of the fixed, configuration codes. For example: "130054052" would result in an error because the "052" prefix is already used by the configuration codes. However, "05" is acceptable because this sequence does not appear in any of the configuration codes (the match must be for all digits).

<b>Blank Annunciate</b>	<spi prefix> + <059> ; <1/0>	Enable/Disable blank track annunciate
default	130059	interrogate status
	1300590	disable blank track announce
	1300591	enable blank track announce

The blank annunciate flag allows the user to enable or disable the blank track annunciator. When enabled, the blank track annunciator simply responds with "T N xx" (where xx = track #) any time that a blank system track is played. If disabled, a blank track will not generate any response to a play command. The factory default enables the blank track annunciator feature.

<b>Track Interrupt Mode</b>	<spi prefix> + <069> ; <mode>	Enable/Disable play track interrupt
default	130069	interrogate
	1300690	no interrupt
	1300691	DTMF interrupt
	1300692	COS interrupt

There are three interrupt modes available on the FF-8070:

<u>RESPONSE</u>	<u>DESCRIPTION</u>
"I N T Cancel"	<mode> = 0, No interrupt allowed -- all tracks will play to completion
"I N T D T M F"	<mode> = 1, Only interrupt if a DTMF digit is detected
"I N T C O S"	<mode> = 2, Interrupt if DTMF or COS detected during play

These modes allow the user to set the play interrupt mode for their DVR. <mode> = 1 is most generally recommended for users who do not want COS interrupt of DVR tracks because it still allows an interrupt mechanism that is available (pressing a DTMF digit) to terminate a track play if desired.

<b>Save Config. Flags</b>	<spi prefix> + <067800>	Set configuration flags to EEPROM
default	130067800	

This command "saves" the status of the configuration flags register. On reset, this register is recalled from EEPROM so that the contents can continue to reflect the user's desired setting. The configuration flags save the Blank annunciate flag and the interrupt mode. Changes made to these settings will not be retained until saved with this command. Also, the auto erase time is saved with this command.

<b>Clear Mail Codes</b>	<spi prefix> + <0581800>	Clear mail suffixes
default	1300581800	

This command should be executed anytime that the voice mail command codes are to be changed. This resets the function codes to the factory defaults which can help reduce difficulties that may be encountered with the FF-8070 code checking procedure.

<b>Auto Play delay</b>	<spi prefix> + <0580> ; <t>	Set or interrogate the auto play delay
default	1300580t	

This command is used to set the auto play delay from <t> = 0 to 9 minutes. The auto play delay affects tracks 100 and 101 and prevents them from being played if a user enters the "List active messages" command within the time set by this command. The factory default is 3 minutes.

<b>Auto Erase delay</b>	<spi prefix> + <0582> ; <t>	Set or interrogate the auto erase delay
default	1300582t	

This command is used to set the auto erase delay from <t> = 0 to 255 hours. The auto erase time is attached to each voice mail message when it is recorded. When the time expires, the message is automatically erased. <t> = 0 hours disables the auto erase feature -- the factory default time is 255 hours, or a little over 10 days. This parameter must be saved using the **Save Config. Flags** command.

## FF-800 Interface Programming

The FF-800 allows any of the system tracks to be entered into speech messages on the FF-800 via the "[SPI]" speech phrase macro (word# 182). When the message is processed by the FF-800, the

appropriate DVR track is played to the repeater output. DVR tracks may be mixed with CW, repeater speech, and repeater courtesy tones. Also, there are two special track numbers that can be used to interrogate the status of the mail box (for ID bulletins, tail messages, etc...). These track numbers are as follows:

<u>track#</u>	<u>Description</u>
100	List all active headers. There is no response if there are no active slots in the mailbox .
101	If there are active mail slots, a play of track#101 responds with system track#02 ("messages waiting..."). Otherwise, there is no response.

The syntax for the [SPI] phrase is "[SPI] a t" where "a" is the DVR SPI address (6) and "t" is the track number to be played. The following examples illustrate speech phrase command entry on the FF-800:

From the terminal interface:

```
>MES 0 [SPI] 6 7 [SPI] 6 101 [SPI] 6 100 [SPI] S
[SPI] 6 7 [SPI] 6 101 [SPI] 6 100 [SPI] S
>
```

This message would be suitable for an ID bulletin and would play track 7 first (which would contain a recording of the repeater ID) and then play track#02 if any mail box slots are active followed by a list of the active mail box headers. The "[SPI] S" speech macro is used to suppress the repeater ID that follows all ID bulletins. If the user wants the ID to occur (i.e., there is no ID recorded in the DVR track) then this phrase macro would be omitted.

A sequence suitable for a tail message is as follows:

```
>MES 10 [SPI] 6 101
[SPI] 6 101
>
```

This will play track#02 if there are any mail box messages and can be assigned to a tail message to provide an additional alert to users of mail box traffic.

The formats are similar if the message is programmed via the DTMF text editor. From the word list the user can note that the [SPI] phrase macro is word# 182, and this is the number used to enter the phrase macro.

```
enter the control security command, followed by the config security command.
enter "<cnfgpfx>580" -- response:"TXT Enter"
enter "182*6*7*182*6*101" -- response:"<track#7> < IF MAIL, then play track#2>"
enter "182*6*100*182*83*" -- response:"<IF MAIL, then list headers>"
```

Note: the code for "S" = 83, thus "182\*83\*" = the ID suppress macro. The parameter(s) following the 182 code must be entered in the same transmission of the text or they will not be parsed correctly. Also, if there are no messages, or if the programmed track is not yet recorded, there will be no response for the text interrogate functions.

Refer to the FF-800 manual for more information on text message entry and message management.

## FF-8070 Command Examples

The FF-8070 is configured at the factory for the amount of memory installed, and the number of mail box tracks is set to 3. The user may wish to modify the mail box assignments or change the user defined command codes. The following examples illustrate how to modify the configuration

and demonstrate the operation of the FF-8070. All examples assume that the FF-800 has its default prefix designations:

The FF-8070 is configured at the factory for the amount of memory installed, and the number of mail box tracks (3 mail box tracks is the factory default). The user may wish to modify the mail box assignments or change the mail box command codes. The following examples illustrate how to modify the configuration and demonstrate the operation of the FF-8070. All examples assume that the FF-800 has its default prefix designations:

- Turn off the mail box and test track:

1300530

response: "Set M T Off"

- Set the number of mail box tracks to 3:

1300537

response: "Set M T Three"

- Set lop values

130017

response: "D V R"

130051200

response: "Set Stop Two Hundred"

130022

response: "Set In B"

13005160

response: "Set Stop B Sixty"

130021

response: "Set In A"

- Set configuration password code

Ground P3-3

13005\*159

response: "P F X"

13009

response: "O K"

130051

response: none

130\*\*\*

response: "Test"

13009159

response: "O K"

130051

response: "Stop Two Hundred"

13005\*

response: "P F X"

record a test track

after track is recorded, the 8070 will replay to verify  
set lop end to 200ms (0.2 sec)

set aux input

set aux lop end to 60ms (0.06sec)

set pass code to "159"

lock security

try to interrogate lop end

do DVR test

unlock security

clear pass code

Be sure to remove the jumper from P3-3 after the pass code has been programmed -- note that this connection is not required to unlock security, it is only required to allow the security code to be changed.

## Adjustments

The FF-8070 is adjusted at the factory to balance the record level between the main and aux. inputs. Note that the FF-8070 should not require adjustment by the user once the FF-800 and repeater levels have been adjusted. The following procedure is for reference in the event that adjustments become necessary.

There are two input level adjustments on the FF-8070: VR1 is the main input level, and VR2 is the aux input level (VR3 is not installed). Refer to the parts placement diagram in appendix B for locating these controls. The simplest means for adjusting the DVR is to use the DVR audio test function to record/play test tracks and an oscilloscope connected to one of the FF-800 audio outputs (P4-1, 3, 5, or 7) or a service monitor on the controller output -- if neither instrument is available, use an amplified speaker or receiver tuned to the repeater output. While recording, monitor the signal level on the scope and compare this to the playback level. If VR1 is properly adjusted, the playback from the DVR will have the same level as the record operation. Repeat this process while adjusting VR1 until the record and play levels are as close as possible.

The aux input level (VR2) is slightly more difficult to adjust since the DVR audio is redirected to the phone during a control autopatch. Also, if a second telephone is not available at the repeater site, another person must assist from a remote location to provide control commands and test audio over the control autopatch. For this adjustment use an oscilloscope or an amplified speaker to monitor the DVR audio at P3-7. Adjust VR1 First and then have the operator that will be on the control autopatch record a test message in one of the system tracks (use the main input for this track). When the operator establishes the control autopatch connection, they must issue the **Input Source Set** command to switch the DVR to the aux input (<spi6 #22>). The operator on the control autopatch will alternately perform an **Audio Test** and **Play system track** of the test track recorded earlier. By comparing the track recorded from the "main" input with the test track from the "aux" input, the person at the repeater site can adjust VR2 to balance the two inputs. The operator on the control patch must continuously rerecord the **Audio Test** track so that the new input level can be compared to the main input level (via the **Play system track** command). Also, note that the aux audio is affected by digital POT#6 on the FF-800, and therefore this adjustment should be completed prior to adjusting VR2 on the DVR.

## APPENDIX A: FF-8070 WIRING

The connections to the FF-8070 are all accomplished via 10 conductor ribbon cable. There are two cables provided, one for the power/audio (connects P3 on the DVR to P25 on the FF-800) and one for SPI communications (connects P5 on the DVR to P7 on the FF-800). The only remaining connection is that of a back-up battery to P2 of the DVR.

For external connections, use shielded or twisted pair cable along with the provided housings and crimp pins. Cut the cable to the shortest possible length and strip back the outer sheath 1 inch. Unravel the braid and twist together as shown below and remove the foil inner shield (if present).

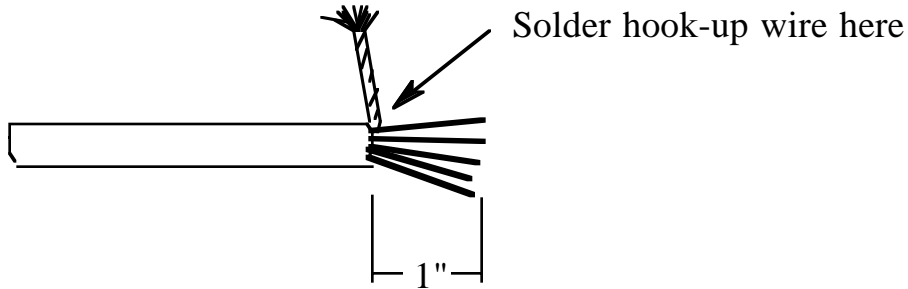

Solder a short piece (1 or 2 inches) of hookup wire to the shield as shown above and cut off the remainder of the shield. Cut this wire even with the others and trim 0.1" of insulation from the end of each wire. Using a pair of needle-nose pliers, crimp the exposed conductor into a molex pin as shown at (1) below. Apply a small amount of solder to establish a good connection. If too much solder is applied, it could wick down to the end of the pin at (4) -- this will make the pin difficult to insert and it may not retain properly. If this occurs, the pin should be discarded and another installed in its place. After all pins are secured, crimp at (2) around the insulation for strain relief.

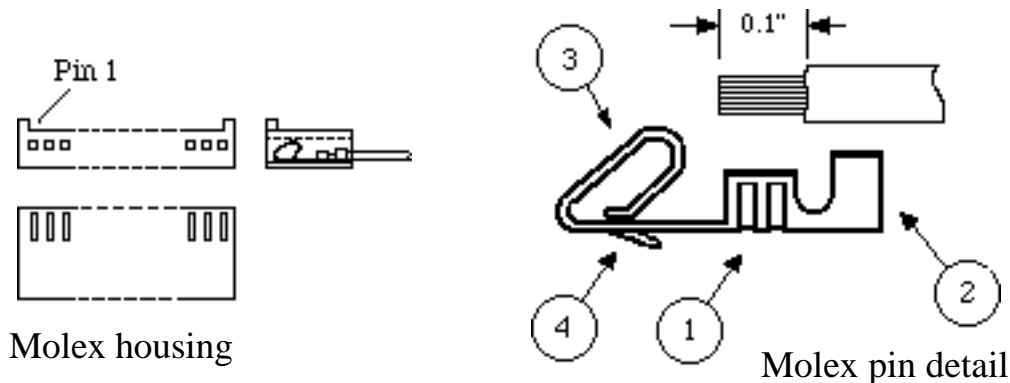

The shield wire should connect to the GND connection of the specific housing. When inserting the pin into the housing, be sure that the contact loop at (3) is oriented toward the tabs on the housing as shown above.



## APPENDIX B: FF-8070 Track Allocation

The track allocation command <061> is used to more finely define the allocation of DVR memory. The basic allocation command <060800> is executed at the factory and allocates the 100 system tracks as 10 banks of 10 tracks each. In each bank, the first six tracks are 5.9 seconds long, while the remaining four are 11.9 seconds long. With this allocation scheme, the only way to get access to all 100 tracks is to add the FF-8070EXP expansion memory card. However, most applications do not require this much memory, so all that is required is to reallocate some or all of the system memory.

The first step is to determine how many tracks of different lengths are required. Use the <061\*nn> code to de-allocate all tracks starting with and following track number "nn" -- it is usually advisable to start at track "00" and reallocate all tracks at once, but this is not required. The <061nn\*tt> code is used to allocate <nn> tracks at <tt> seconds each. This continues until all desired tracks are allocated, or until the 100th track is allocated (at which point the DVR will no longer accept allocation inputs and an "Abort" response is sent). The "Abort" response simply means that all of the 100 system tracks have been allocated. The reallocation process should be done before recording tracks because each reallocated track is erased in the process. The allocation data is stored in nonvolatile memory which is specified to maintain data for up to 10 years. Thus, if the DVR loses power, the tracks must be rerecorded, but the time allocations are retained.

## APPENDIX C: Adding DRAM

Adding memory to the DVR is relatively simple. However, the process requires that all power be removed from the DVR board -- this will necessitate that all tracks be rerecorded after the memory is added. Memory is added in groups of four 1 Megabit DRAMS (411000, 511000, or equivalent) as follows:

first group: U1, U11, U21, & U31  
second group: U2, U12, U22, & U32  
                  :                  :  
                  :                  :  
                  :                  :  
last group: U8, U18, U28, & U38

Any supplier of computer memory is likely to supply the DRAMS used on the FF-8070. The access time is not critical (anything faster than 120ns is sufficient). FF-Systems can also provide additional memory if another source is not available.

After the installation, the user must execute the **DRAMS Installed** and **MAIL Tracks** commands to tell the DVR how much memory is installed and to reconfigure the mail box system. **MAIL Tracks** must be executed even if there is no change to the number of voice mail tracks.

For systems that require more memory than the 10 minutes available on the FF-8070, a memory expansion card is available that piggy-backs on to the FF-8070 (part# FF-8070EXP). This card provides room for an additional 32 DRAMS or about 10 more minutes of record time. Contact FF-Systems for more information.

## APPENDIX D: Schematic and Parts List

### FF-8070 Parts List

C1 - 32, 37, 41, 61	0.1 $\mu$ F ceramic capacitor, 50V
C33, 36, 38, 39, 42	1.0 $\mu$ F nonpolarized electrolytic capacitor, 35V
C34, 35	100 pF ceramic capacitor, 50V
C44, 57, 58, 59	10 $\mu$ F electrolytic capacitor, 25V
C51	330 $\mu$ F electrolytic capacitor, 35V
C52, 53, 56	100 $\mu$ F electrolytic capacitor, 25V
R1	10M $\Omega$ , 1/4 watt resistor
R2	510 $\Omega$ , 1/4 watt resistor
R3	470 $\Omega$ , 1/4 watt resistor
R4	1K $\Omega$ , 1/4 watt resistor
R5, 6, 7	20K $\Omega$ , 1/4 watt resistor
R8, 10, 15, 16, 19, 20	10K $\Omega$ , 1/4 watt resistor
R9	5.1K, 1/4 watt resistor
R13	100 $\Omega$ , 1/4 watt resistor
R21	10 $\Omega$ , 1/4 watt resistor
R24, 25	330 $\Omega$ , 1/4 watt resistor
R17, 36, 37	20K $\Omega$ , 1/8 watt SMD resistor, 1206 type package
R38	1M $\Omega$ , 1/8 watt SMD resistor, 1206 type package
VR1 - 2	10K $\Omega$ potentiometer
RP1 - 4	1.5K x 9 resistor pack, common bus
RP5 - 6	10K x 5 resistor pack, common bus
D1, 2, 6	1N4001 Diode, 50PIV
D7	1N4735, 6.2 V zener diode, 1/2 watt
Q1	PN2907A PNP transistor
Z1	15V tranzorb circuit protector
Y1	4.00MHz ceramic resonator
U1 - 8, 11 - 18, 21 - 28, 31 - 38	411000 1 M x 1 bit DRAM I.C.
U9, 19, 29, 39	74HC244 Octal bus driver I.C.
U10, 20, 30, 40	74HC138 1 of 8 decoder I.C.
U43	TMS3478NL CVSD record/playback I.C.
U44	MC68HC711E9-CFN2 microprocessor I.C.
U45	LM7805 +5V regulator I.C.
U46	MF4-50 switched capacitor filter I.C.
U47	LF353 op-amp I.C.
U49	4002 Dual 4 input NOR gate I.C.
U50	4066 quad analog switch I.C.
U51	ICL7660 dc-dc converter I.C.
U52	MC34064P-5 voltage monitor I.C.
U53	4040 ripple counter I.C.
P2	3 pin Molex header
P3	2 pin jumper header (9 pin Molex on some boards)
P3a	10 pin IDC header
P5	10 pin IDC header

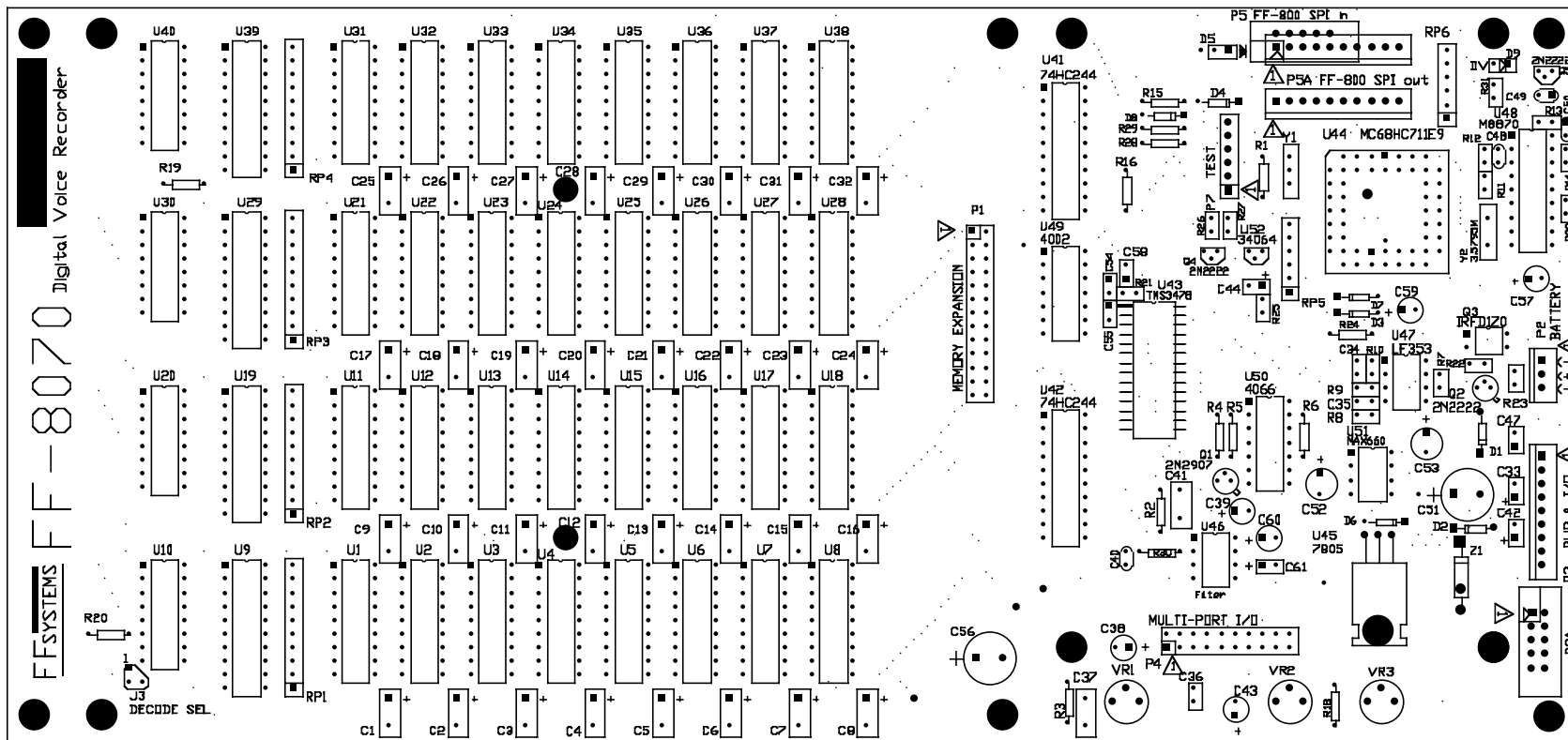

FF-8070 Component Layout

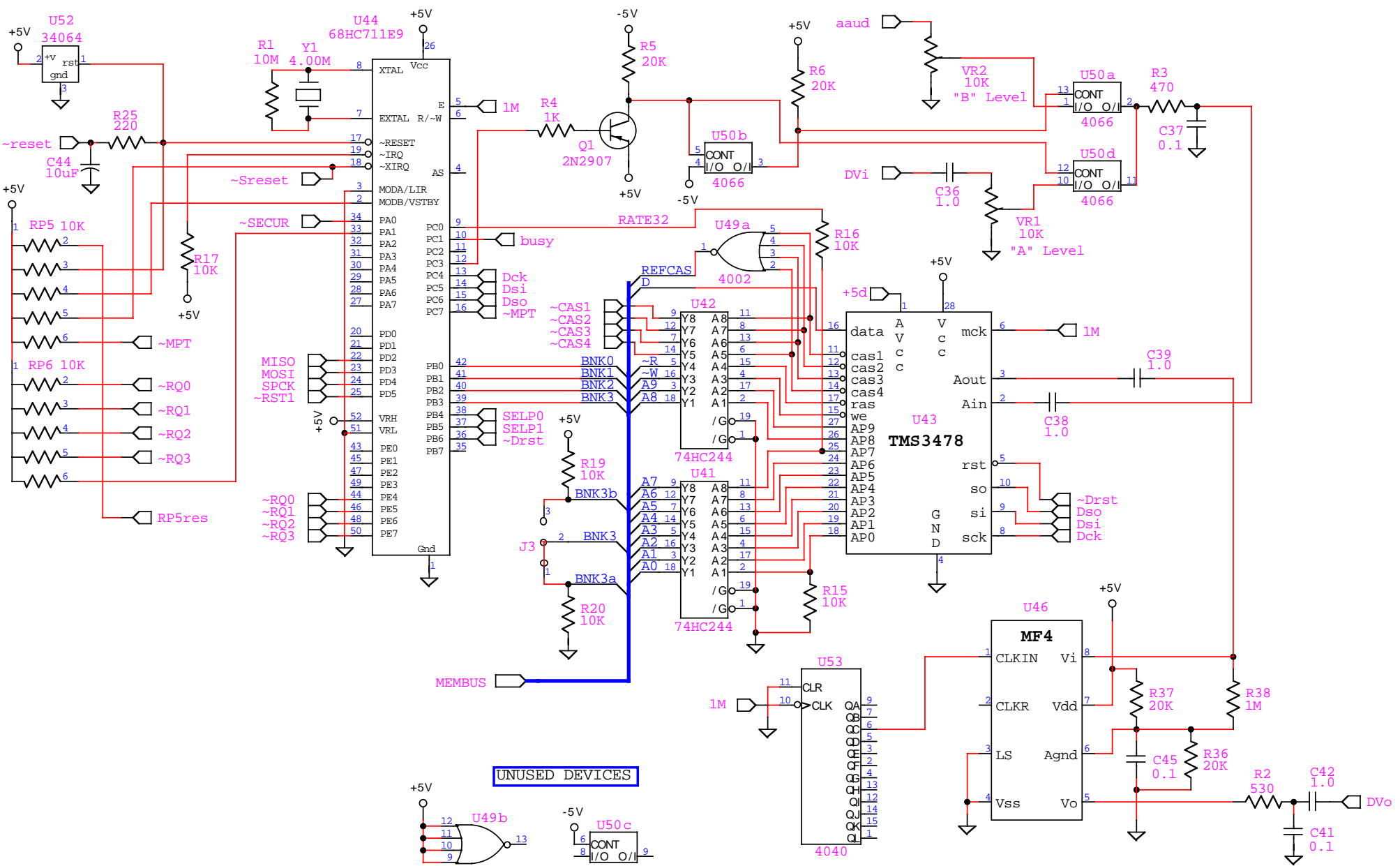

<b>FF Systems</b> <i>"Affordable Repeater Control Solutions"</i>	Drawn by	jmh	<b>FF Systems</b> P.O. Box 5533 Round Rock, TX 78683 joe@rollanet.org www.rollanet.org/~joe/	8070.schem	
	Date	6/30/95		512-365-1120 (v)	Page size B
	Des. chk	6/30/95			SHT 1 OF 4
	chk'd by	jmh		TITLE:	REV: F
	Rel. date	12/14/02	<b>FF-8070 D.V.R.</b>		

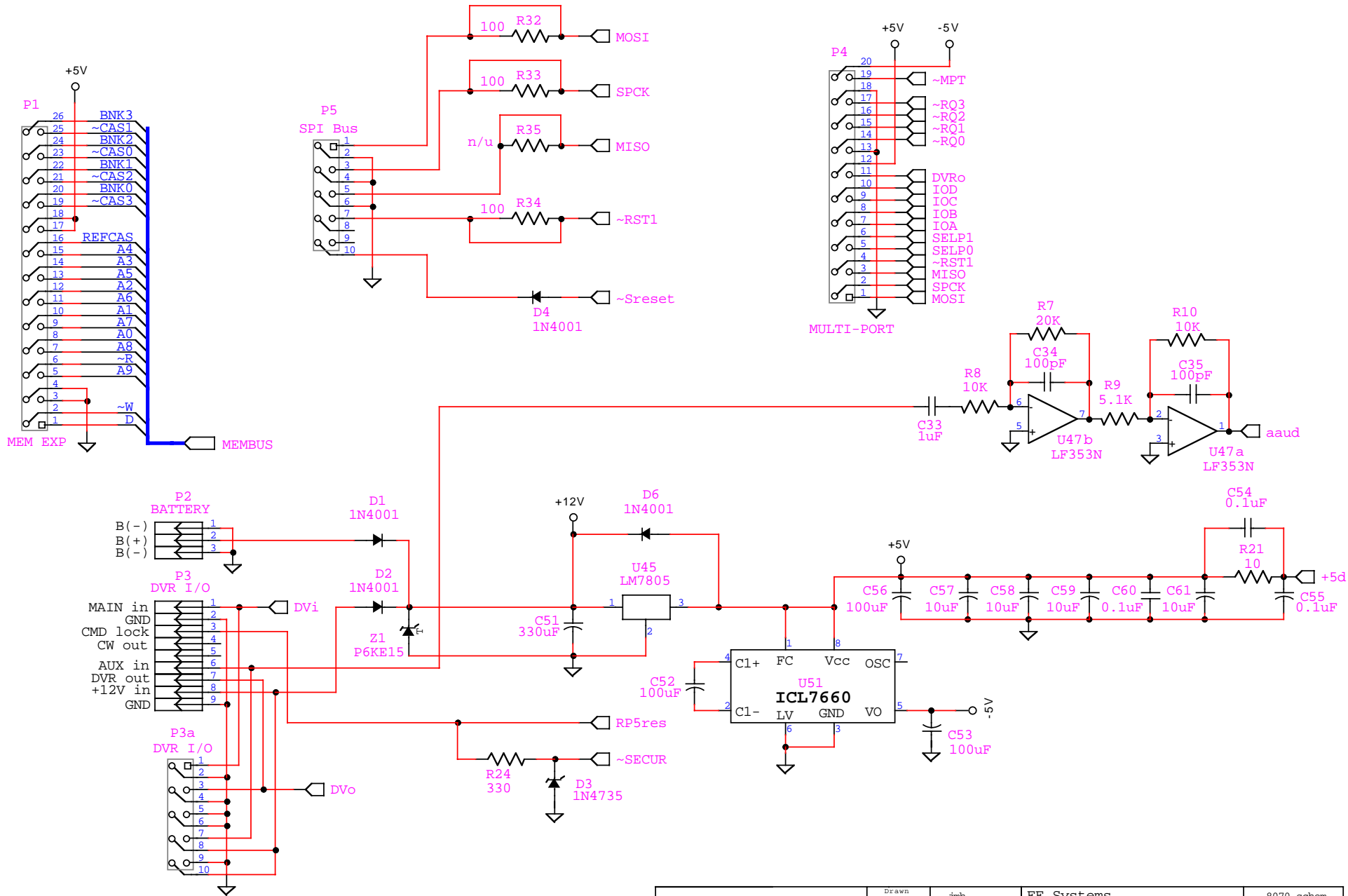

<b>FF Systems</b> <i>"Affordable Repeater Control Solutions"</i>	Drawn by	jmh	FF Systems	8070.schem
	Date	6/30/95	P.O. Box 5533 Round Rock, TX 78683 joe@rollanet.org www.rollanet.org/~joe/	512-365-1120 (v) Page size B
	Des. chk	6/30/95	TITLE:	SHT 2 of 4
	chk'd by	jmh	FF-8070 D.V.R.	REV: F
	Rel. date	12/14/02		

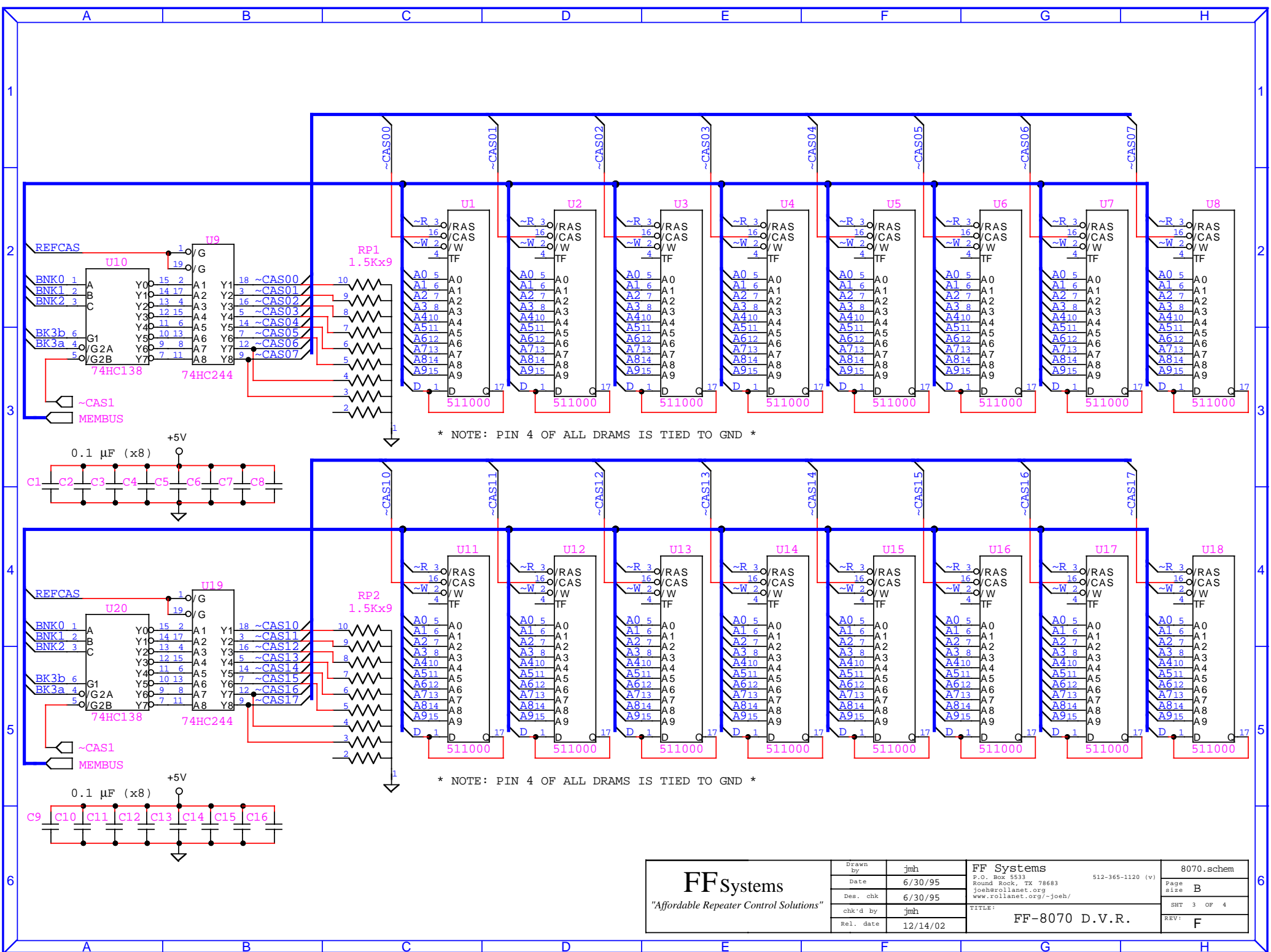

\* NOTE: PIN 4 OF ALL DRAMS IS TIED TO GND \*

\* NOTE: PIN 4 OF ALL DRAMS IS TIED TO GND \*

<b>FF Systems</b> <i>"Affordable Repeater Control Solutions"</i>	Drawn by	jmh	<b>FF Systems</b> P.O. Box 5533 Round Rock, TX 78683 joe@rollanet.org www.rollanet.org/~joe/	8070.schem	
	Date	6/30/95		512-365-1120 (v)	Page size B
	Des. chk	6/30/95			SHT 3 OF 4
	chk'd by	jmh		TITLE:	REV: F
	Rel. date	12/14/02		FF-8070 D.V.R.	

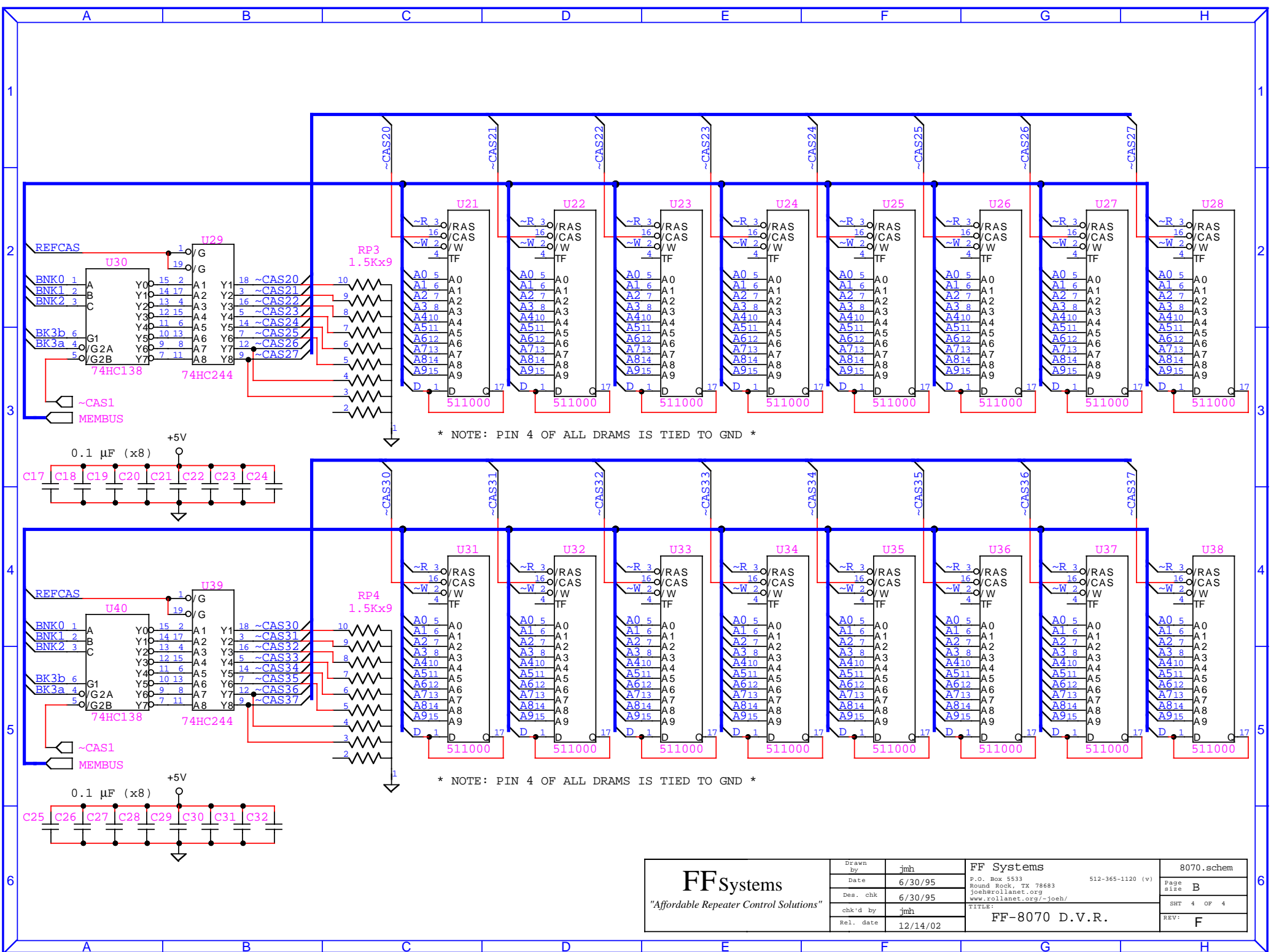

\* NOTE: PIN 4 OF ALL DRAMS IS TIED TO GND \*

\* NOTE: PIN 4 OF ALL DRAMS IS TIED TO GND \*

<b>FF Systems</b> <i>"Affordable Repeater Control Solutions"</i>	Drawn by	jmh	FF Systems P.O. Box 5533 Round Rock, TX 78683 joeh@rollanet.org www.rollanet.org/~joeh/	8070.schem
	Date	6/30/95		512-365-1120 (v)
	Des. chk	6/30/95	TITLE:	SHT 4 of 4
	chk'd by	jmh	FF-8070 D.V.R.	
	Rel. date	12/14/02	REV:	F

## FF-8070 Legacy Installation Supplement

For FF-8070 units that are manufactured for FF-800 revE or F controllers, the following cables are provided:

- One (1) power/audio cable
- One (1) battery backup cable
- One (1) SPI cable
- One (1) Female DB-9 (solder type) w/ metalized hood

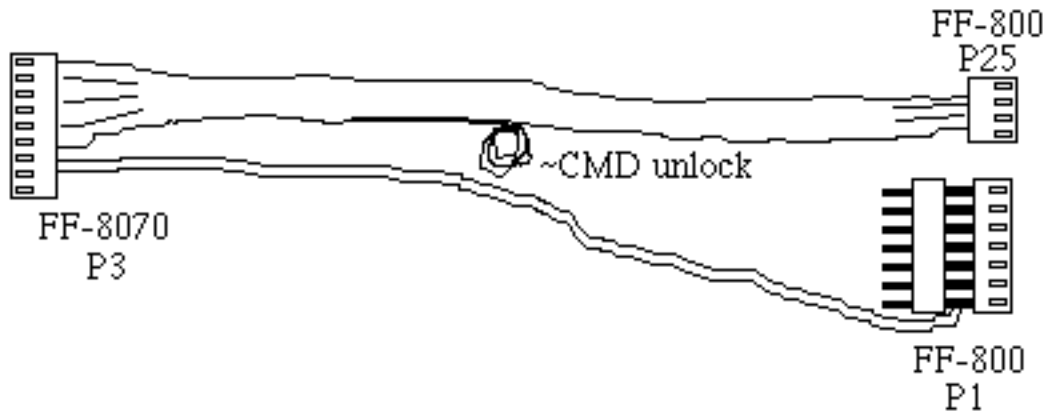

POWER/AUDIO Cable pictorial

The FF-8070 should be installed adjacent to the FF-800 (the P7 side). Install the DVR P3 connector and the FF-800 P25 connector. Remove the existing FF-800 P1 connector and install the daisy chain connector from the DVR cable. Re-install the existing power connector on the top of the DVR daisy chain connector.

The FF-8070 ~CMD unlock signal is provided as an unconnected wire that is coiled and secured near the center of the power/audio cable. The end of this wire has a molex crimp pin installed with a short section of heat shrink tubing to prevent it from shorting to adjacent circuitry. This wire can either be connected to the FF-800 P5 connector (one of the logic outputs), to a user supplied switch, or left as is (if no DVR security code is desired).

If the ~CMD unlock signal is connected to the FF-800 P5, use the associated logic output to allow programming of the DVR security code. The FF-800 logic output commands should be placed in sysop secure mode (see the FF-800 manual for details on configuring the FF-800 logic output commands to require control unlock security).

If there are any connections to the FF-800 P7, remove the existing connection and install the supplied ribbon cable. Move the existing P7 connection to the DVR P5a connection. The other end of the DVR ribbon cable goes to FF-8070 P5.



The battery backup cable provides a DB-9 connection for an external battery:

DB-9 pinout

1	BATT+ (8-12V)
2	n/c
3	n/c
4	n/c
5	n/c
6	BATT-
7	BATT-
8	BATT-
9	BATT-